

HPT20S

Instruction Manual

Hand Pallet Truck with Scale

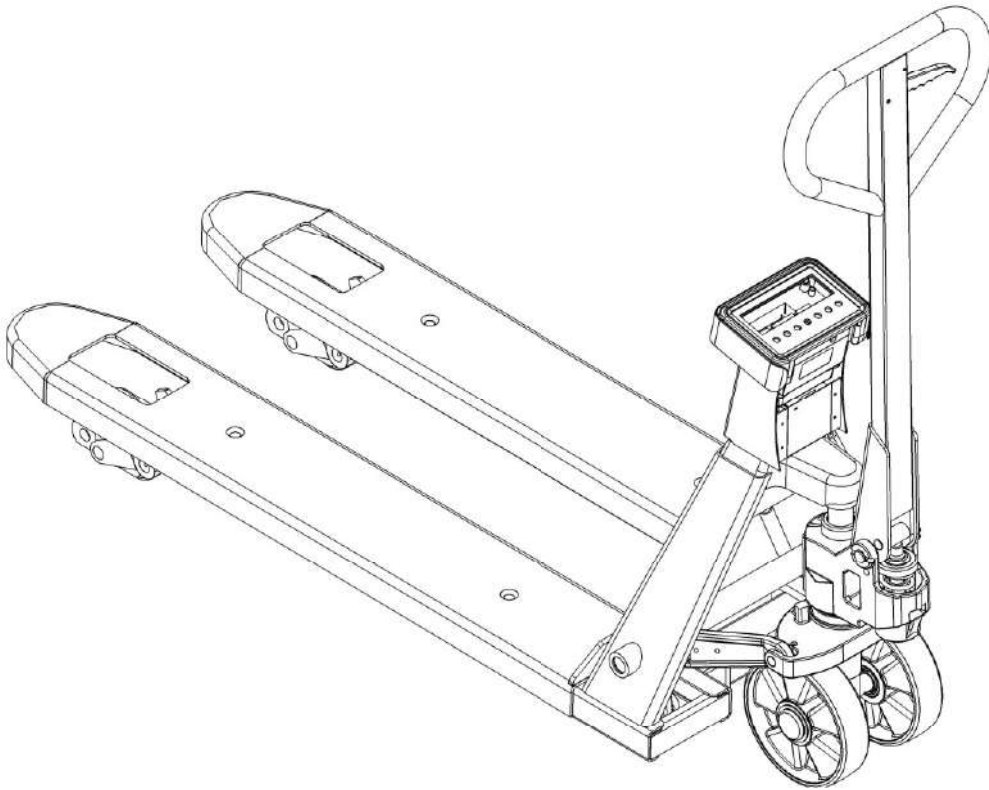

Note: Operator MUST read and understand these operating instructions and warning labels before using this hand pallet truck.

Thank you for using this pallet truck with scale. Your pallet truck with scale is made of high quality steel and was designed to give you durable, reliable and easy experience to use product. For your safety and correct operation, please carefully read and understand this instruction manual before using it.

NOTE: All of the information reported herein is based on data available at the moment of printing. We reserve the right to modify our own products at any moment without notice and incurring in any sanction. So it is suggested to always verify possible updates.

1. GENERAL SPECIFICATIONS

Capacity	2000 kg/ 5000 lbs	
Power Source	6V DC	
Environment	General purpose, dry	
Operating temperature	-10°C — 40°C (14°F to 104°F)	
Min/Max fork height	76mm/190mm	85mm/200mm
Features weighing accuracy	±1.0kg for loading 2,000kg	
Width over forks	570mm/ 690mm	555mm/ 690mm
Fork Length	1150mm/ 1220mm	

2. OPERATING PROCEDURES

2.1. Assemble the indicator

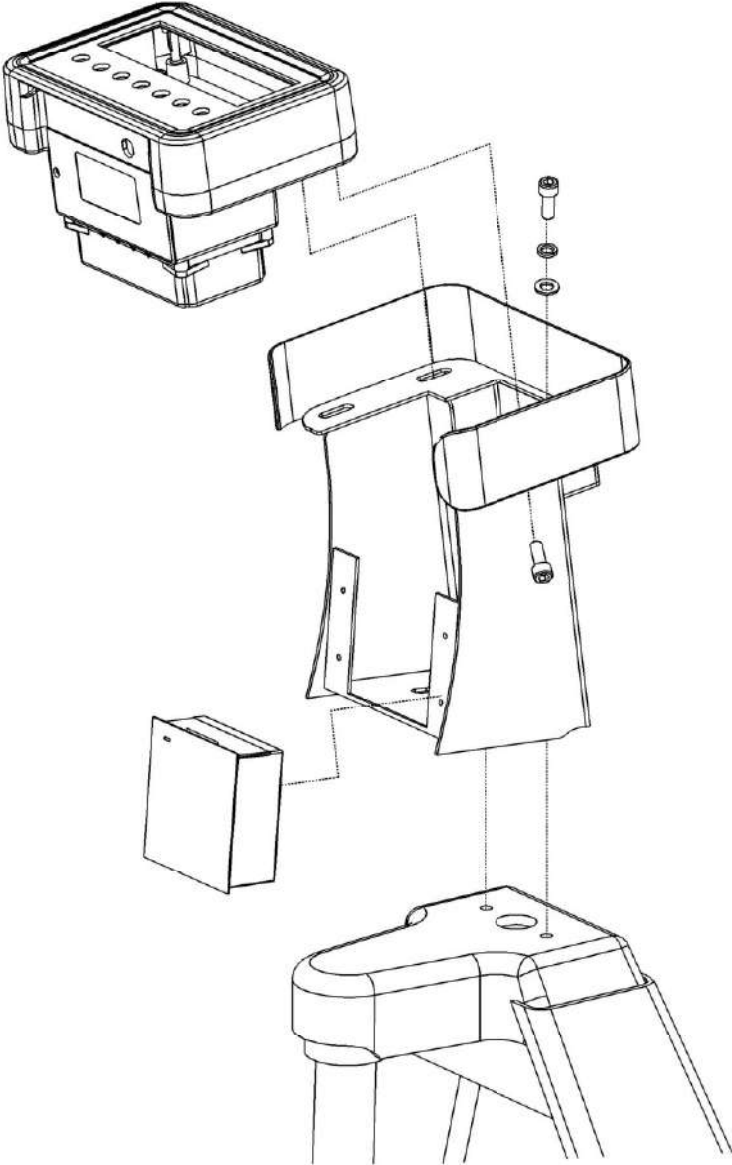

2.2. Assemble the tiller and pump unit

2.2.1. Insert the tiller into the right piston of the pump (303), then assemble the axle (G105) on the tiller, and hit the axle with a hammer from the right to the left, to make the tiller well connected with the hydraulic pump (see figure 1).

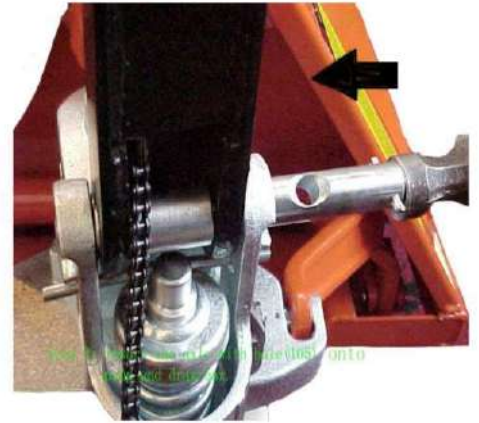

Fig.1

2.2.2. Put the finger tip control (G117) to the lower position, then pass the adjusting nut (G104), adjusting bolt (G103) and chain (G102) through the hole of the axle (G105) manually.

2.2.3. Press the tiller (G110) down, take away the spring which fixes the spring cap (302).

2.2.4. Put the finger tip control (G117) to the lift position, then raise the lever rod (319) with the pin and insert the adjusting bolt (G103) into the front slot of the lever rod (319). Note: keep the adjusting nut (G104) underneath the lever rod.

2.2.5. Tap another spring pin (G106) into the axle with hole (G105) with a hammer. The tiller is then assembled to the pump.

2.3 Adjust the release device

On the tiller of the truck, you can find the finger tip controls (G117) of three positions:

Lift Position - pull up the finger tip control

Neutral Position - place the finger tip control at center position

Lower Position- push down the finger tip control

The three positions of the finger tip control have been adjusted before delivery. If there are some changes due to unexpected reasons, make adjustment according to the following instructions:

3.1. Place the finger tip control (G117) in the **Neutral Position** and swing the tiller up and down. At this time, the forks should neither go up nor go down. If:
A) the forks go up, turn the nut (G104) clockwise until the forks stop lifting.
B) the forks go down, turn the nut (G104) counterclockwise until the forks stop lowering.

3.2 Pull up the finger tip control (G117) in the **Lift Position**, and swing the tiller up and down. At this time, the forks should lift steadily. If not, turn the nut (G104) counterclockwise until it starts lifting, then repeat step 3.1.

3.3 Push down the finger tip control (G117) in the Lower Position. If the forks can not go down. Turn the nut (G104) or screw (318) clockwise until the lifting control (G117) can lower the forks. Then follow step 3.1 to check the neutral position to make sure the nut (G104) and screw (318) are in place.

3. OPERATION OF WEIGHING PALLET TRUCK

3.1 Accurate weighing

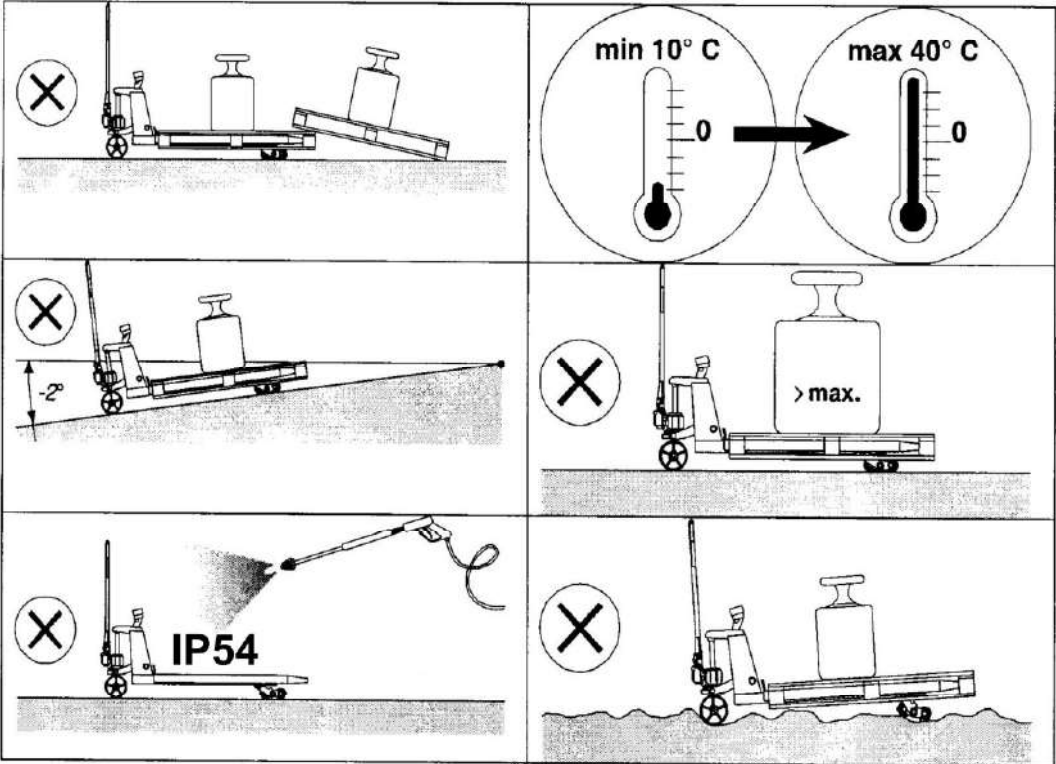
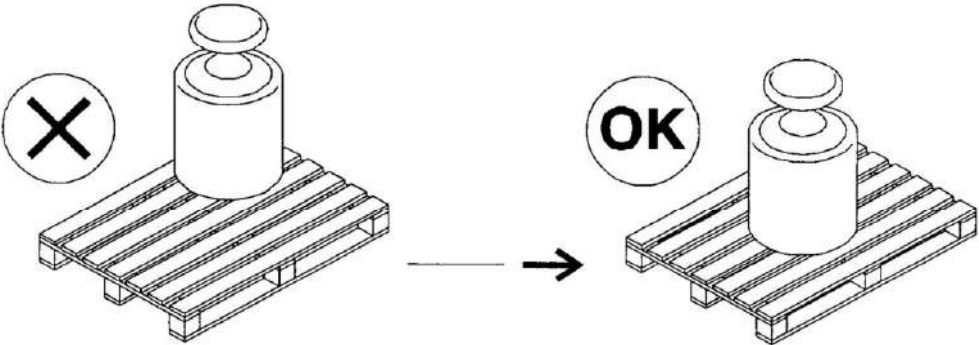

3.2 1 (Net) + 2 (Tare) = 3 (Gross)

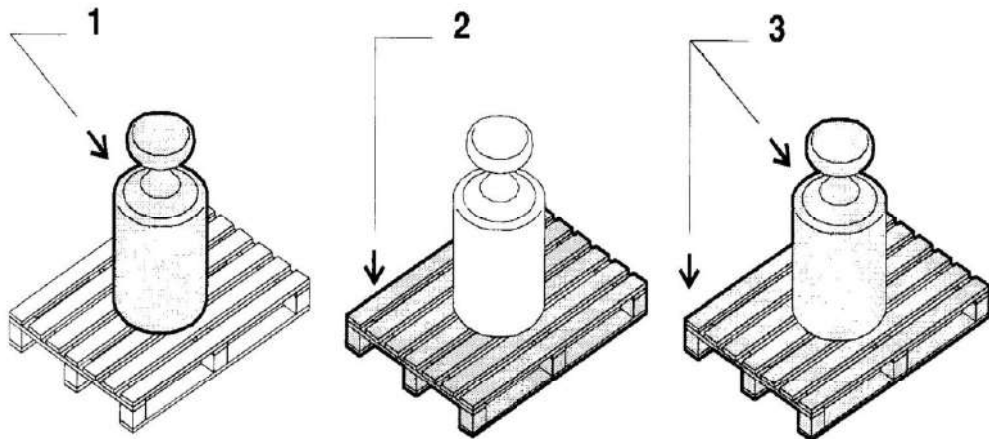

3.3 Errors



HELP

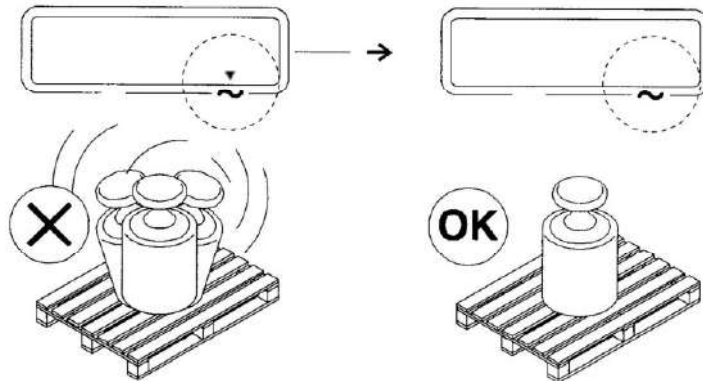

HELP

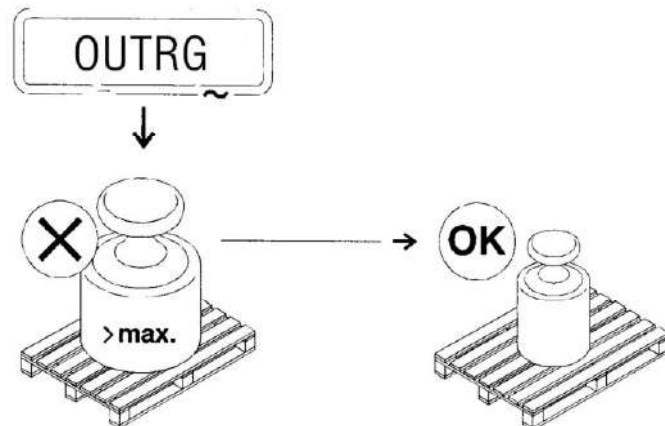

3.4 Zero and tare functions

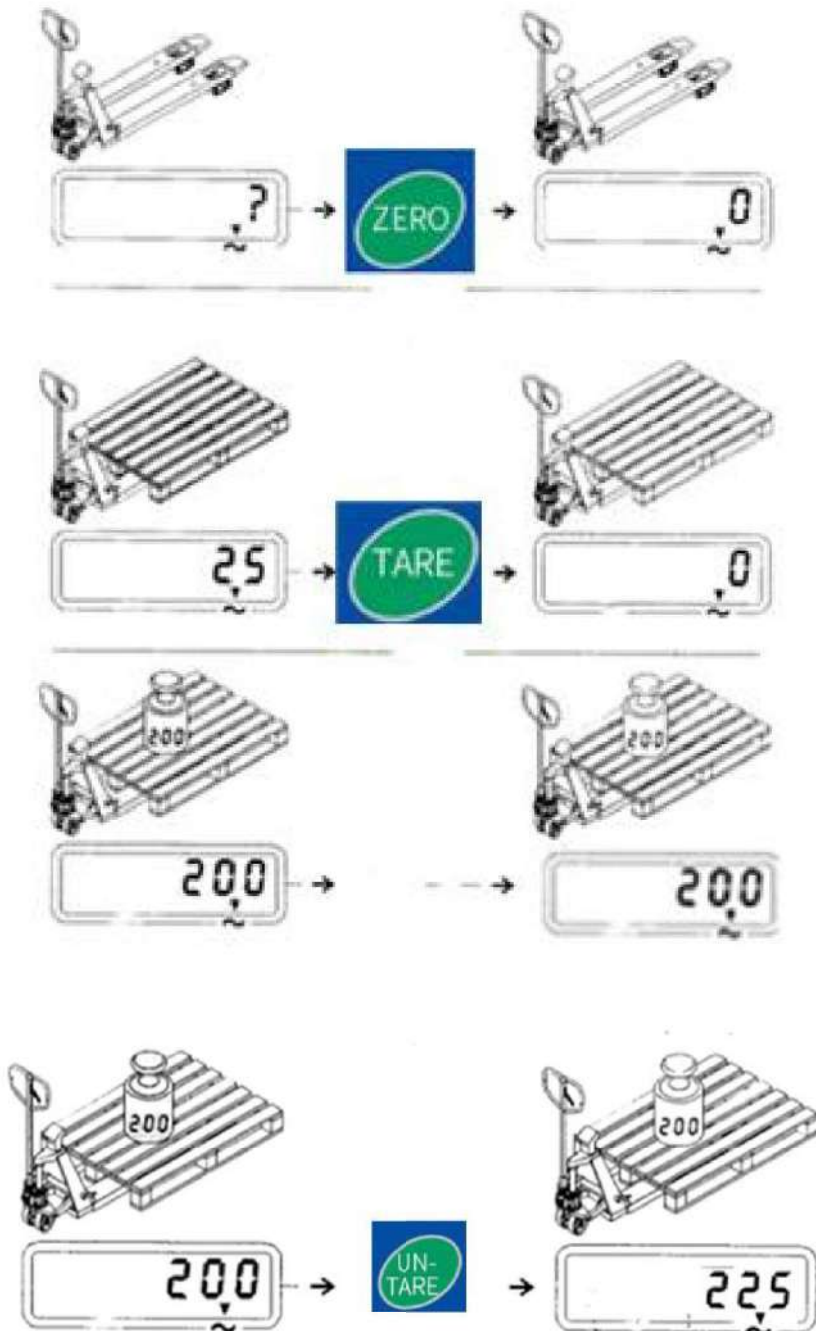

3.5 Summation (total) function

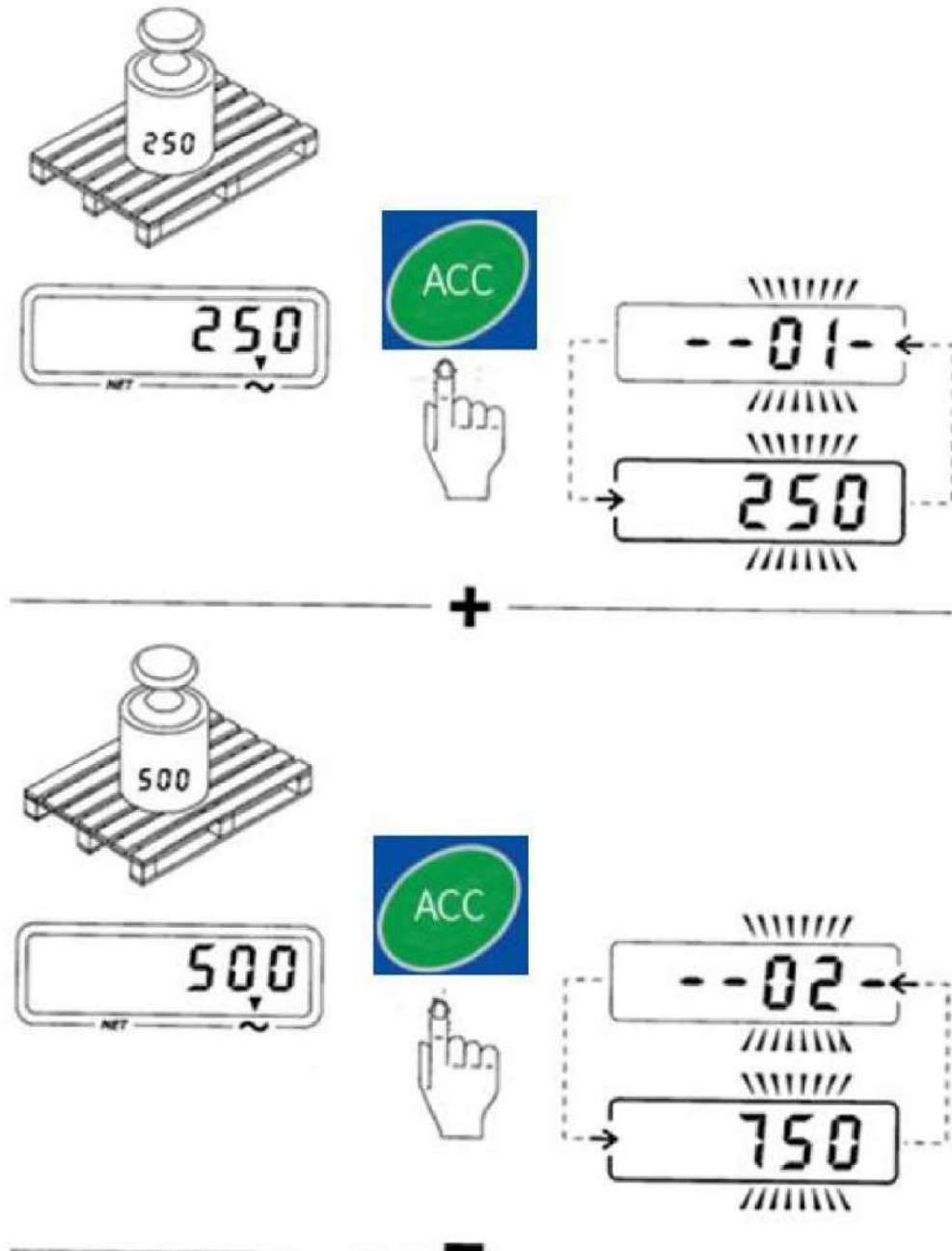

3.6 Printer (Optional)

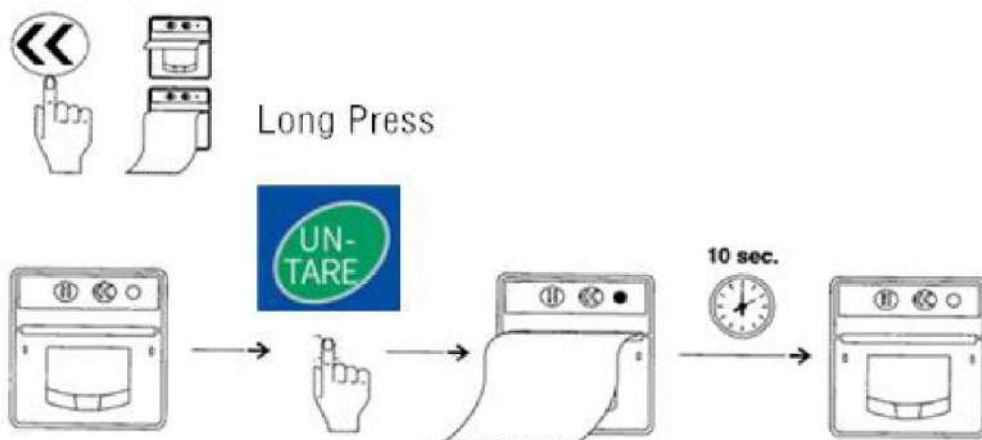

Printer	Thermal Printer	Print speed	Up to 65 mm/sec (Max)
Function	Front side paper feed, easy to install paper	Temperature range	-10~55°C
Paper	Thermal roll, roll diameter Maximum 50mm, width 58mm	Dimensions	85x85x54mm
Resolution	8 dots/ mm, 384 dots/ line	Power supply	DC5V, DC5V-9V (optional)

3.7 Printout (Option)

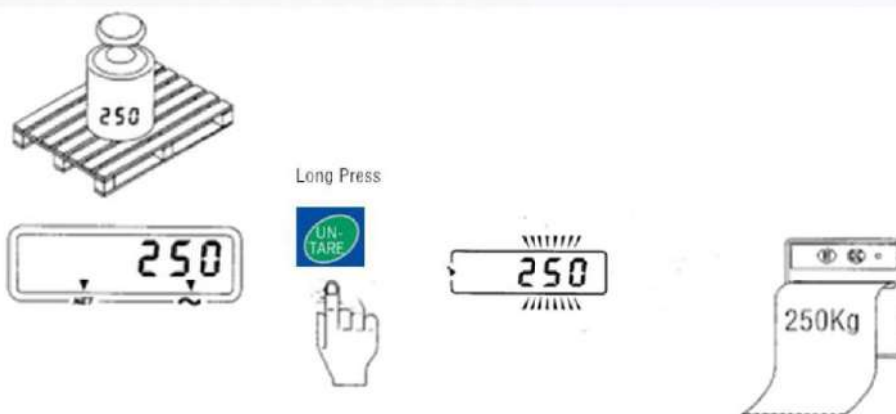

3.8 Paper replacement

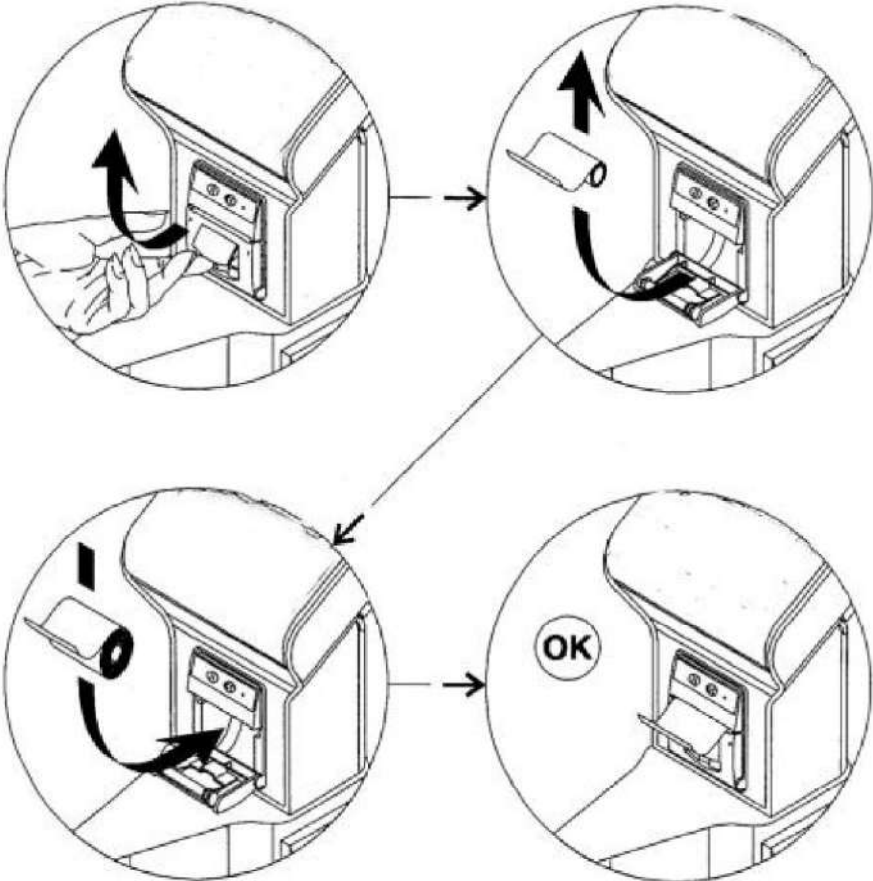

4. Indicator display

4.1 Button Screen Check

Operating Method:

Before power on, long press and hold **Zero** button, then press **On/Off** button, the device will enter hardware check state. Release the **Zero** button when screen shows “CKHAR” 。

When the screen displays “0 KEY”, press **Zero** button, the screen shows “0 OK”;

Then “T KEY”, press **Tare** button, the screen shows “T OK”;

Then “U KEY”, press **lb/kg** button, the screen shows “U OK”;

Then “P KEY”, press **Gross** button, the screen shows “P OK”;

Then “A KEY”, press **Total** button, the screen shows “A OK”;

Then “H KEY”, press **Hold** button, the screen shows “H OK”—If operation succeeded, it means all buttons are OK.

When screen displays “P–BL”, press Tare button, the screen will display all contents and backlight on. Press Tare button again to empty the screen and backlight off. Press Tare button again, the screen shows “HCKOK”. If your operation and manual coincide, it means the screen and backlight OK.

4.2 Default Unit Settings

When screen displays "SETUP", press the **Tare** (Confirm) button to confirm entering parameter setting mode. Check the default unit setting when the screen displays "UNIT". Then press the **Tare** (Confirm) button to confirm entering this mode.

Operating Method:

Press the **Tare** (Confirm) button to enter Default Unit Settings when in UNIT interface. Check the default unit at the right of the screen. Press the **Gross** (<—>) button to switch the unit. Press the **Tare** (Confirm) button again to confirm when the screen shows the desired unit.

After setting the default unit, next is to set the backlight. When the screen displays BLMOD, press **Tare** (Confirm) button to enter backlight mode setting, or press **lb/kg** (Cancel) to cancel and enter the next setting.

4.3 Backlight Mode Settings

When the screen displays BLMOD, press **Tare** (Confirm) button to enter backlight mode setting, or press **lb/kg** (Cancel) button to cancel, and go to the next setting.

Backlight mode setting is set disabled by default, and can be enabled by long press **Zero** (Backlight) button when in weighing mode. When backlight is on, the screen will display the backlight cursor (the triangle above LIGHT).

Operating Method:

When in BLMOD interface, press **Tare** (Confirm) button to enter backlight settings. Then press **Gross** (<—>) button continuously to switch the display content. It will loop the below 3 modes.

1) BL ON: means backlight mode on. When in weighing mode, long press **Zero** (Backlight) button to turn on backlight, and will last for 10 seconds.

2) BL OFF: means backlight mode off. When in weighing mode, long press **Zero** (Backlight) will be of no use.

3) BL AT: means auto backlight mode. When in weighing mode, the backlight will be automatically on once weight change has been detected. Backlight will last 10 seconds if the weighing goes stable.

Press **Tare** (Confirm) button to confirm the setting and go to the next setting.

4.4 Calibration

Calibrate the device with Calibration function if the weighing result is not correct (Calibration unit is kg). Calibrate only one time during each operation.

When the screen displays CALBN, it's the calibration mode. Make sure there's no goods on the truck's forks. Press **lb/kg** (Cancel) button to cancel and enter the weighing mode after setting the parameters. Or press **Tare** (Confirm) to enter calibration settings. (Note: It's suggested to press **lb/kg** (Cancel) button to cancel the calibration and enter Weighing mode if the user only wants to set the default unit or BLMOD when the weighing result is correct.)

Operating Method:

Press **Tare** (Confirm) button to enter Calibration mode when in CALBN interface. Put the weight on the truck's forks when the "---" cursor stops flickering and displays "00000" on the screen. Continuously press **Zero** (Input) button to loop the numbers from 0 to 9 for the digit with cursor below it, and press **Gross** (<—>) button to change the cursor position. Input the value of the weight by pressing **Gross** (<—>) button and **Zero** (Input) button, and then press **Tare** (Confirm) button to confirm. Calibration completed when the screen displays CALOK.

4.5 Battery Replacement

Use 6V/4.5A rechargeable batteries (68.5mm*46.5mm*100mm).

First remove the screws of the battery cover, then replace the used batteries with the new ones. At last put back the battery cover and fix it with screws.

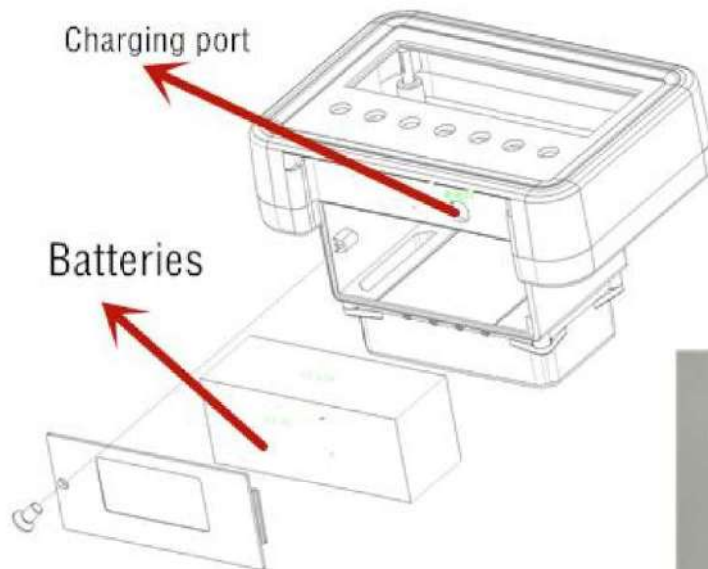

4.6 Indicator operation panel

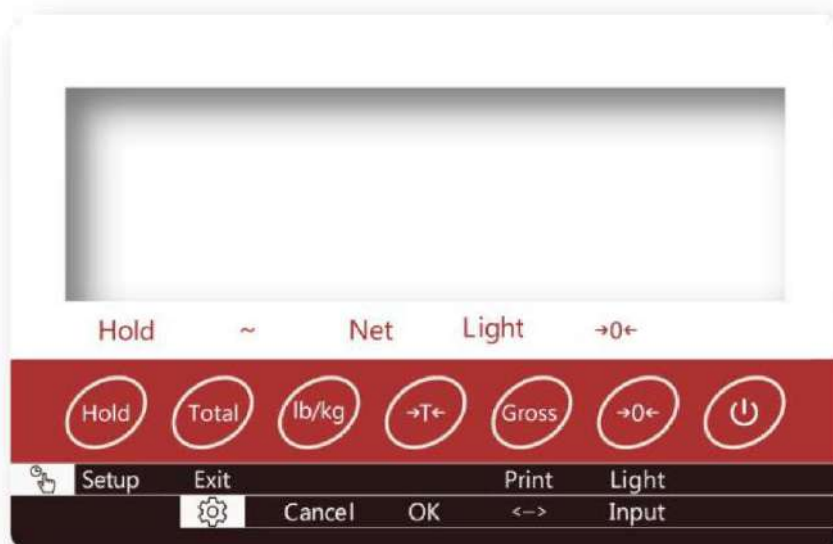

Note: this scale has 5 dynamic cursors: Hold (lock cursor), ~ (dynamic cursor), Net (net weight cursor), Light (backlight cursor), →0← (zero cursor) and 7 buttons: "Hold", "Total", "lb /kg", "Tare", "Gross", "Zero", "On/ Off".

Short press or long press the button, or press two buttons at the same time to achieve different functions.

4.7 Installation of Sensors

1) Before the installation of the sensors, please make sure to power off the device head. The sensors will be in loop detection state if the device head is powered on. Operation with electricity will cause wrong data.

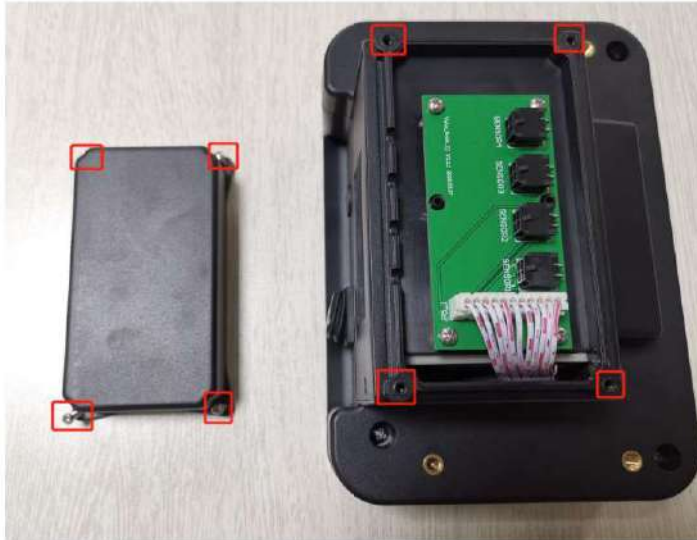

2) Remove all M3 Phillips screws at four corners of the sensor box. Open the box and join the 4 sensors to the 4 connectors.



3) Find the black waterproof rubber ring and white cable tie at the end of each sensor connector harness.

4) Put the white cable tie into the box and the rubber ring into the slot for outgoing cables.

5) Put back the cover and fix it with screws.

4.8 Button Functions

1) Single Button Function



Short Press - lock / unlock the weight value displayed on the current screen ; in weighing mode, press the "Hold" button on the operation panel, the current weight displayed will be locked, and the lock cursor will show at this time. If the weight is in the locked state, press the "Hold" button again to unlock it. Then it will return to the weighing state, and the lock cursor disappears. If it is in the weight lock state, functions like tare, total, zero will be rejected.

Long Press – enter into parameter setting mode.



Short Press - weight accumulation button. (1) Under weighing mode, the final weight will be the value when the dynamic cursor disappears. Press the "Total" button, the weight will be accumulated, and the accumulation time will be +1 , the screen will alternately display the accumulation time and total weight; (2) When the goods are unloaded, the device value returns to zero, place the next goods to accumulate; (3) When there is no goods on the trunk's forks, press the "Total" button to display the total accumulation times and total weight.

Long Press - the screen displays “ Σ OFF” and exit the accumulation mode.



Short Press – switch the display unit of current weight.



Short Press - Under the Gross Weight state, take the current weight as the tare value, and the device changes to the Tare mode.



Short Press – Under the Tare mode, restore the tare value and the device changes to Gross Weight mode.

Long Press - if there is a printing module, the current weighing result can be printed out. Note: Do not remove the goods when printing.



Short Press - reset the display value within allowed reset range (only allowed to reset when the displayed weight is less than 10kg).

Long Press - control the backlight according to the mode of the backlight setting. if the device is in "BL ON" mode, and the backlight cursor is displayed, long press to the button to turn on the backlight.



Short Press – power on / power off.

2) Button Combinations

Press “**lb/kg**” and “**Gross**” button at the same time to restore factory settings (handle with care).

5. MAINTENANCE

5.1 Hydraulic oil

The hydraulic oil shall be chosen according to the operating environment temperature. The oil type can be ISO VG46 if the environment temperature is 0°C~+45°C; or the oil type can be ISO VG32 if the environment temperature is -15°C~0°C. Please replace the oil level every six months.

5.2 To remove air from the pump

Air may come into the hydraulic pump during transportation, which may cause the failure of hydraulic function on the tiller, and forks fail to lift. Air can be removed by the following way: move finger tip control (117) to the **lower** position, then move the tiller up and down for several times.

5.3 Daily check and maintenance

Daily check of the pallet truck with scale can limit wear as much as possible. Special attention should be paid to the wheels and axles, for example, thread or rags, etc. On the axles may block the wheels. The forks should be unloaded and lowered in the lowest position when the work is over.

5.4 Lubrication

All bearings and shafts are provided with long-life grease at the factory. You only need add long-life grease at monthly intervals or after each time the lubrication points of the truck are cleaned thoroughly.

6. GUIDE ON SAFE OPERATION

6.1 Operator should follow the instructions to operate the truck.

6.2 Do not operate the truck unless you are familiar with it or have been trained to do so.

6.3 Do not operate the truck until you have checked its condition. Give special attention to the wheels, the tiller, the finger lever, etc.

6.4 Do not use on a slopping ground.

6.5 Do not take any people on the pallet truck when moving.

6.6 The operator had better wear on gloves for labour protecting.

6.7 When lift or transport the goods, all the people should be at least 600mm away from the forks.

6.8 The goods shall be evenly distributed on two forks. Load on one fork is not allowed, and the position of goods gravity center should be between two forks.

6.9 Do not load over maximum capacity.

6.10 For others special conditions or areas without protection, the operator should be careful to operate the pallet truck.

7. TROUBLE SHOOTING

No	Trouble	Clause	Fixing Methods
1	The forks can not be up to the max. height.	-The hydraulic oil is not enough.	-Pour in the oil.
2	The forks can not be lifted.	-Without hydraulic oil. -The oil has impurities. -The nut (104) is too high, keep the pumping valve open. -Air come into the hydraulic oil.	-Fill in the oil. -Change the oil. -Adjust the nut(104) or screw (318) (see item 3.4) -Banish the air. (see item 4.2)
3	The forks can not be lowered.	-The piston rod (328) or pump (322) is deformed resulting from partial loading slanting to one side or over-loading. -The fork was kept in the high position for long time with piston rod bared to arise in rusting and jamming of the rod. -The adjusting nut (104) or screw (318) is not in correct position.	-Replace the piston rod (328) or pump (322). -Keeping the fork in the lowest position if not using, and pay more attention to lubricate the rod. -Adjust the nut (104) or screw (318) (see item 3.3)
4	Leakage	-Sealing parts worn or damaged. -Some part cracked or worn into small.	- Replace with the new one. - Replace with the new one.
5	The forks go down without switching on the release valve.	-The impurities in the oil cause the release valve to be unable to close tight. -Some parts of hydraulic system is cracked or bored. -Air come into the oil. -Sealing parts worn or damaged. -The adjusting nut (104) or screw (318) is not in the correct position.	-Replace with new oil. -Replace the damaged parts. -Banish the air. (See item 4.2) -Replace with the new seal parts.

6	Abnormal work on scale	<ul style="list-style-type: none"> - The bolts (251B) scrape the chassis (201B) - The platform (250B) scrapes the chassis (201B). 	<ul style="list-style-type: none"> -Adjust the bolts (251B) -Face lifting the platform.
7	Nothing is showed on the display	<ul style="list-style-type: none"> - The battery power is too low. 	<ul style="list-style-type: none"> -Replace with new battery. -Charge the battery.

NOTE: DO NOT ATTEMPT TO REPAIR THE PALLET TRUCK UNLESS YOU ARE TRAINED AND AUTHORIZED TO DO SO.

Tiller assembly

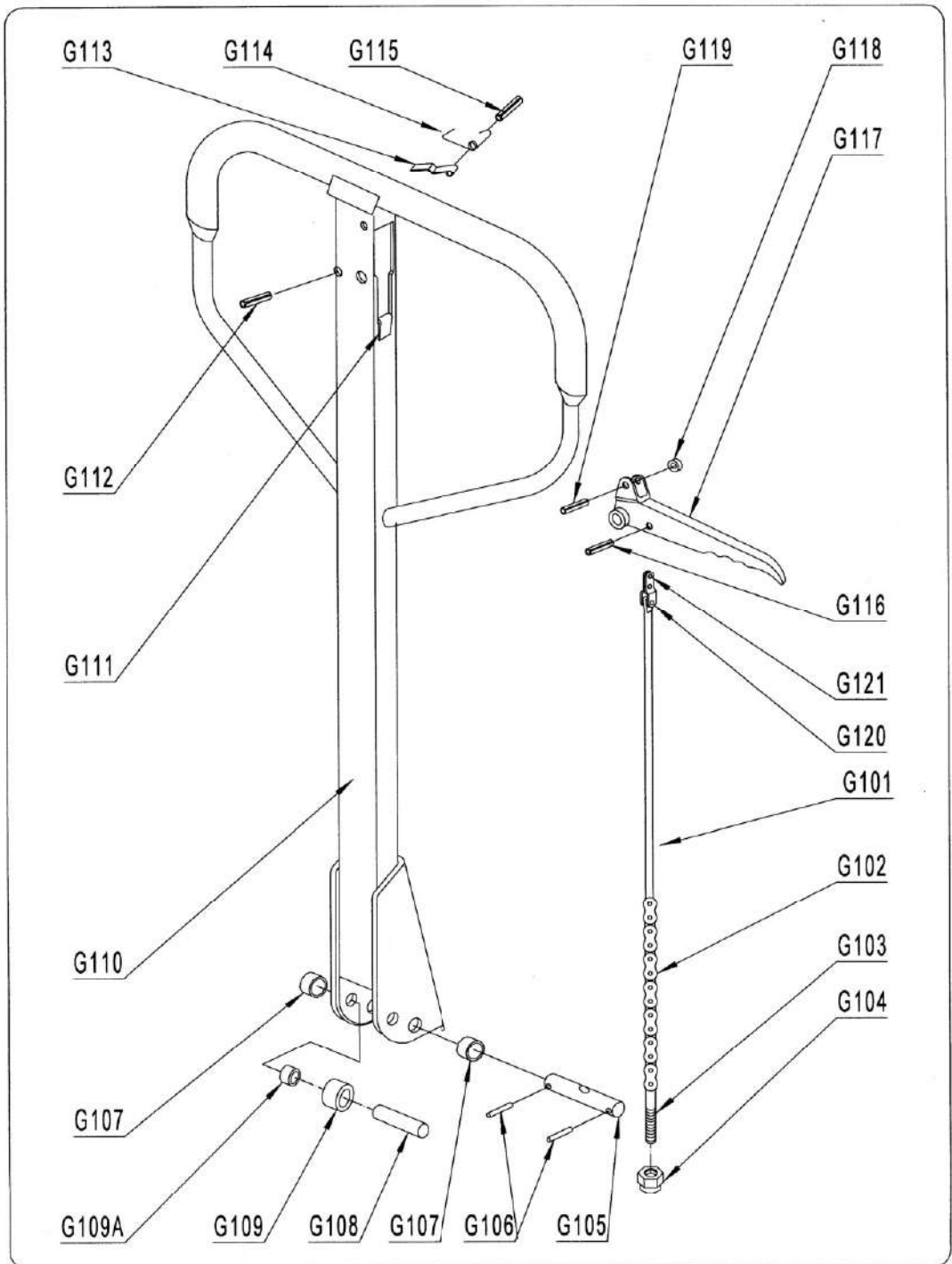

Tiller assembly

No.	Code	DWG No.	Description	Qty.
G101	300511020003	ACA20.2-4	Linking rod $\Phi 6 \times 670$	1
G102	301011020009	GB/T 1243-2006	Roller chain 04C-1-17	1
G103	301011020006	DFA25.3-1 0	Short linking rod	1
G104	910300500002		Nut GB889.1-M5-10	1
G105	300511020002	ACA20.2-3	Axle $\Phi 20 \times 103$	1
G106	910600400027		Cylindrical spring pin 5×35	2
G107	940500200006	QB048.01. 2022.15	Bushing (with shoulder) $\Phi 20 \times \Phi 22 \times 15$ -SF-1	2
G108	300511020000	ACA20.2-1	Wheel axle $\Phi 15 \times 60$	1
G109	300511020001	ACA20.2-2	Pinch roller $\Phi 24 \times \Phi 17 \times 36$	1
G109A	940500100003	QB047.01. 1517.15	Bushing $\Phi 15 \times \Phi 17 \times 15$ -SF-1	2
G110	300511010000	ACA20.2.1	Tiller bar welding (rubber tiller head)	1
G111	301011020007	DFA25.3-11	Rubber part	1
G112	910600400038		Cylindrical spring pin 6×30	1
G113	302511020000	DF25.3-7/B	Folder	1
G114	301011020005	DFA25.3-9	Spring $\Phi 6.6 \times \Phi 1.6 \times 3.6$	1
G115	910600400015		Cylindrical spring pin 4×30	1
G116	910600400009		Cylindrical spring pin 4×14	1
G117	301011020002	DFA25.3-6	Finger tip control	1
G118	301011020004	DFA25.3-8	Roller $\Phi 12 \times \Phi 4.5 \times 10$	1
G119	910600400011		Cylindrical spring pin 4×20	1
G120	301011020001	DFA25.3-5	Linking plate	1
G121	910500400001		Cone head rivet GB868-4x10	1

Chassis assembly

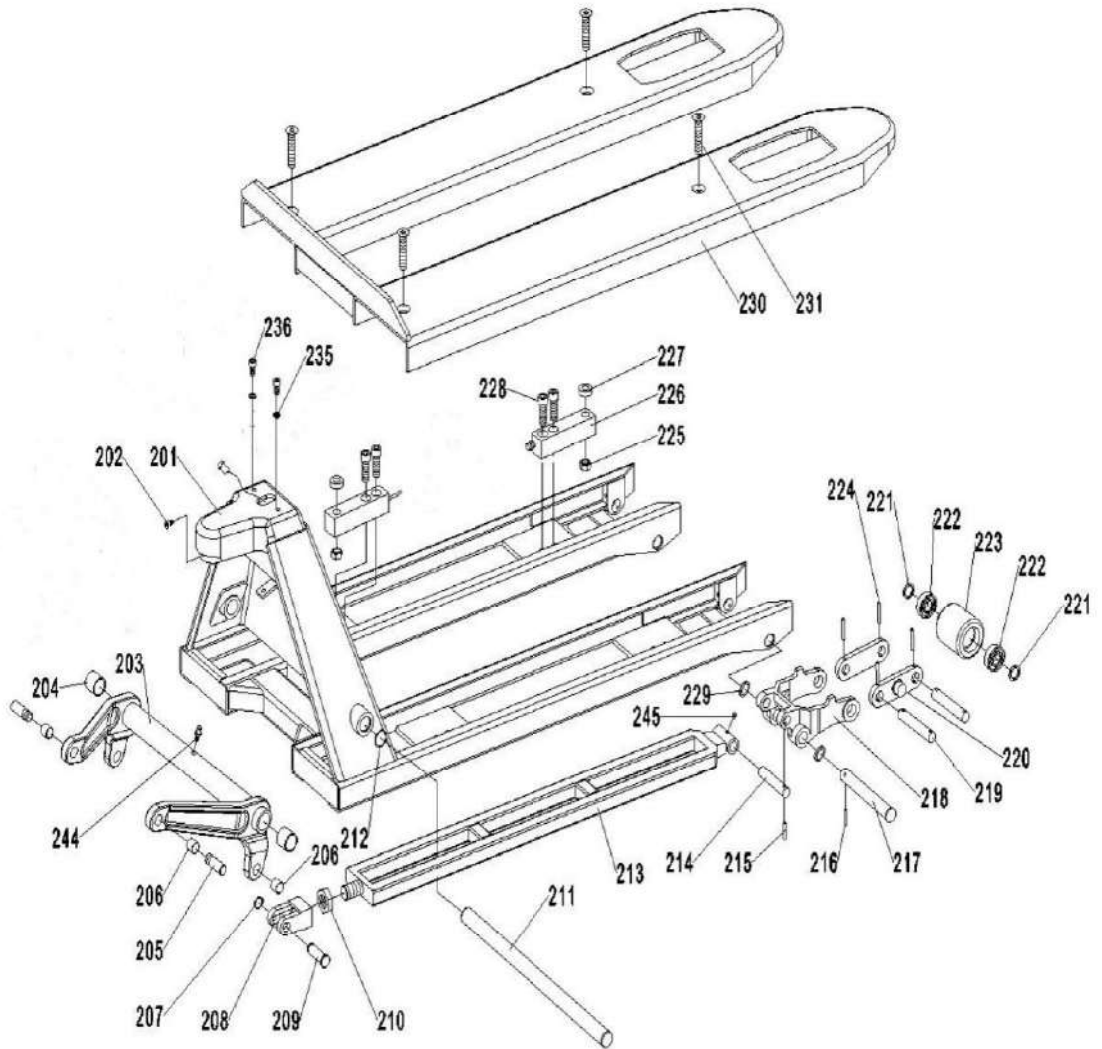

Chassis assembly

No.	Code	DWG No.	Description	Qty.
201	302872010004		Chassis welding (85mm555x1150)	1
	303302072006		Forks unit for economical truck (85mm690x1220)	1
	303302071601		Forks unit for economical truck (75mm570x1150)	1
	303302071602		Forks unit for economical truck (75mm690x1220)	1
202	910200200034		Screw GB70.1-M6x14-8.8	1
203	302872010023	SAC20.3.2_ E	Rock arm welding (540)	1
204	940500100032	QB047.01.2 529.25	Bushing Φ25xΦ29x25-SF-1	2
205	300523520013	ACA20.1-1 2	Axle Φ16x48	2
206	940500100006	QB047.01.1 618.15	Bushing Φ16xΦ18x15-SF-1	4
207	910401300007		Circlip for axle GB894.1-16	2
208	302872020046	SAC20.1-7 E	Push rod fork	2
209	301072020004	DFA25.1-5	Hinge pin Φ16x48	2
210	910300400009		Nut GB6173-M22x1.5-05	2
211	302672020028	SAC20.1-5/ E	Rock arm axle Φ25x476.5	1
212	910401400006		Circlip for hole GB893.1-25	2
213	302672010004	SAC20.1.2_ E	Push rod welding (1150)(L1=875,L2=777)	2
214	301072020000	DFA25.1-8	Axle Φ16x82	2
215	910600400024		Cylindrical spring pin 5x28	2
216	910600400027		Cylindrical spring pin 5x35	2

Chassis assembly

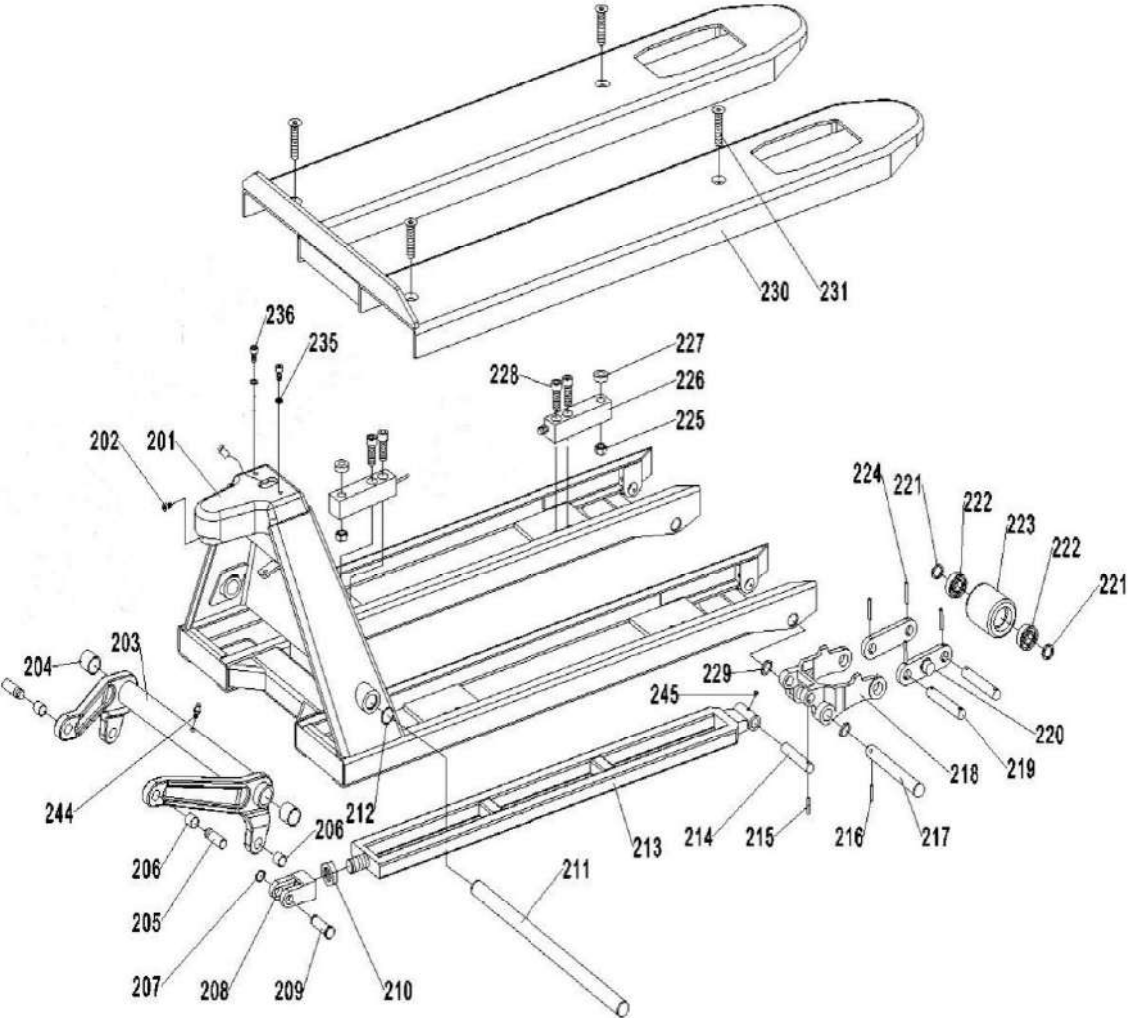

Chassis assembly

217	302672020019	SAC20.1-6/ E	Lever block axle Φ20x155	2
218	301071720003	DFA25.1-1 0	Lever block (75mm)	2
219	302517020001	DFA20.1-11 /D	Wheel axle Φ20x94	4
220	301017020003	DF25.1-14_ D	Linking plate	4
221			Washer	8
222	910700200019		Bearing GB276-6204-2RS	8
223	940300201020		Red PU wheel (iron core) Φ74x70	4
224	910600400027		Cylindrical spring pin 5x35	8
225	910300500006		Nut GB889.1-M12-10	4
226	921800100031		Sensor ESS-210	4
227	302871620048	SAC20.1.8- 2_R	Washer Φ25xΦ13x8	4
228	910200200098		Screw GB70.1-M12x30-8.8	8
229	302872020054	HTW1.1-1	Washer Φ26xΦ20.3x3	4
230	302872010010	SAC20.1.4 _E	Cover plate welding (555x1150)	1
231	941100300004	SAC20.1.8- 1/RAVAS	Screw M12x63-8.8	4
244	911200100005		Grease cup JB7940.2-45°-M6	1

Hydraulic pump unit

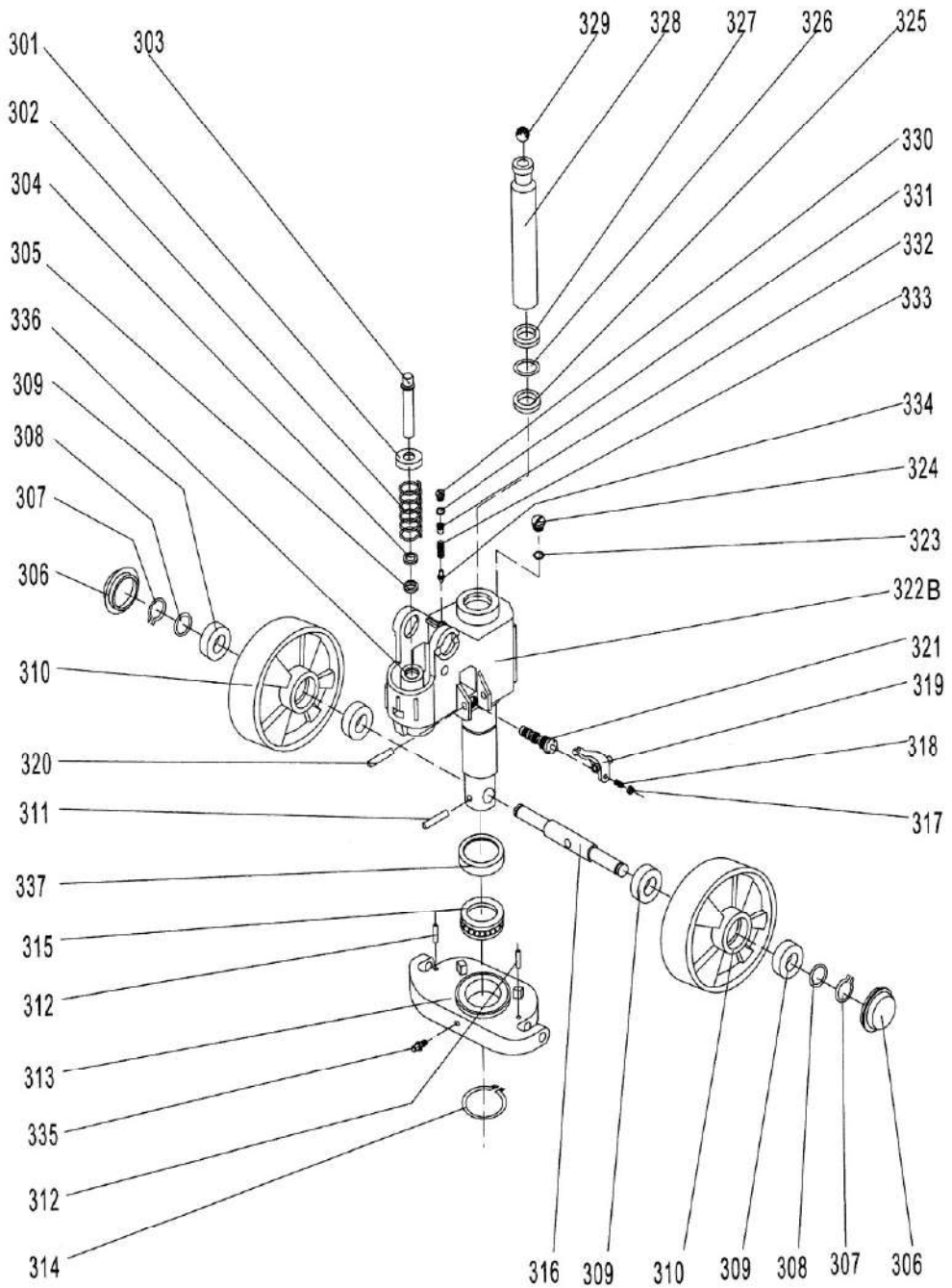

Hydraulic pump unit

No.	Code	DWG No.	Description	Qty.
301	300523520006	ACA20.1-7	Spring cap Φ54xΦ18.5x17	1
302	940400500034	ACA20.1-4	Spring Φ43.3xΦ5.7x87	1
303	300523520005	ACA20.1-6	Piston Φ18x86.5	1
304	910800400010		Dust ring FC18x26x4.5	1
305	910800300012		Seal ring for axle Y18x26x5	1
306	301016520002	DFA25.2.2- 2	Dust cover	2
307	910401300011		3Circlip for axle GB894.1-20	2
308	301016520003	DFA25.1-13	Washer Φ25xΦ20x2	1
309	910700200019		Bearing GB276-6204-2RS	4
310B	940300101011	DF25.2.2-1	Red PU wheel (iron core)Φ180x50	2
	940300105003		White nylon wheel Φ180x50	2
	940300104003		Black rubber wheel (aluminium core) Φ180x50	2
	940300101009		Black PU wheel (iron core) Φ180x50	2
311	910600400047		Cylindrical spring pin 8x45	1
312	910600400025	2	Cylindrical spring pin 5x30	2
313	300523520000	ACA20.1-1	Thrust plate	1
314	910401300025		Circlip for axle GB894.1-52	1
315	910700700002		Bearing GB301-51111	1

Hydraulic pump unit

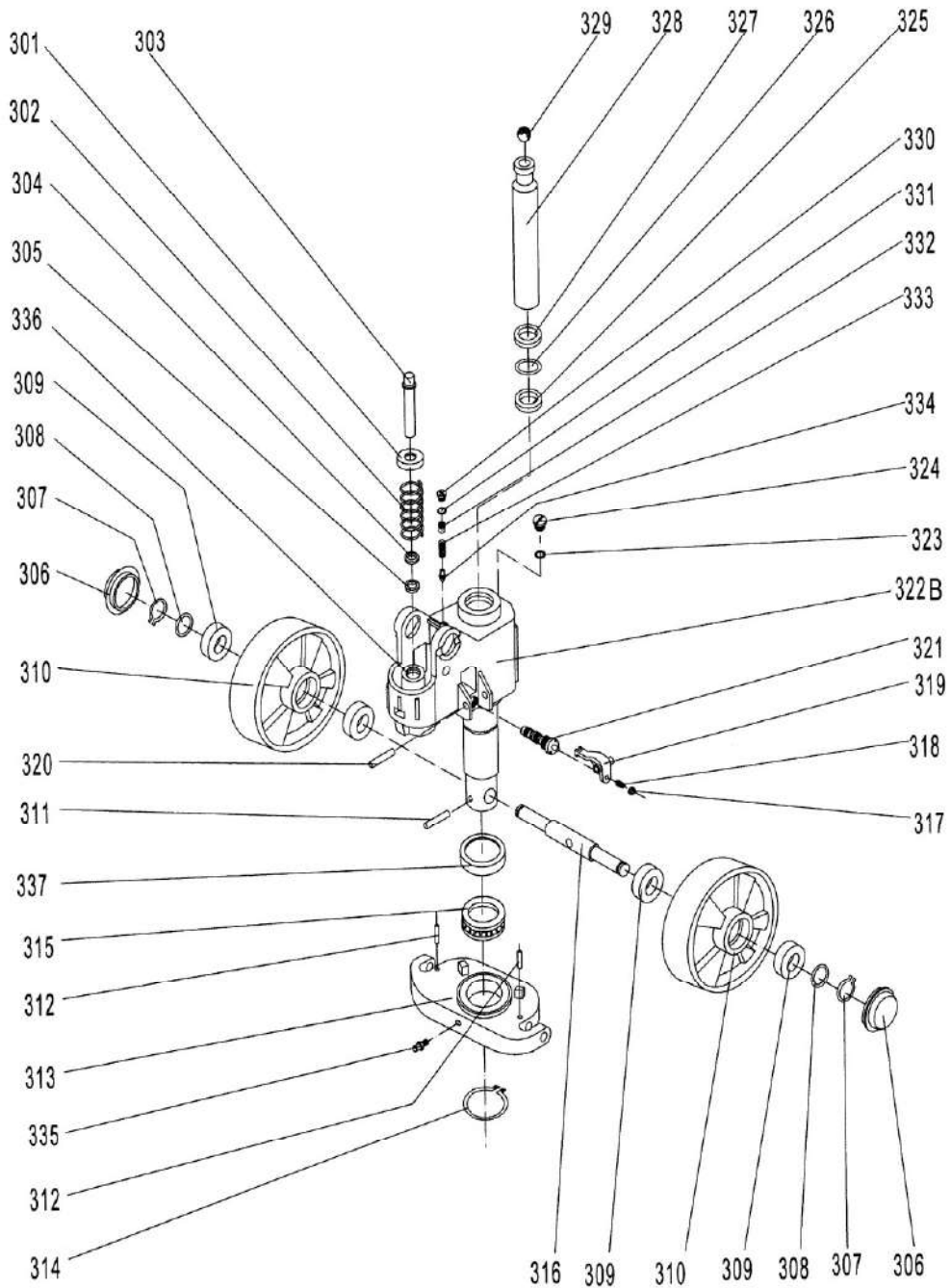

Hydraulic pump unit

316	30051652 0000		Wheel axle Φ 25x180	1
317	91030010 0006		Nut GB6170-M8-10	1
318	91020080 0021		Screw GB77-M8x20-45H	1
319	30052352 0001	ACA20.1-2	Rocker rod	1
320	91060040 0048		Cylindrical spring pin 8x50	1
321	30052351 0003	ACA20.1.2	Hydraulic valve assembly	1
322	31032351 0052	AC20.1.1/DF	Cylinder assembly AC166MM (AC51 pump) 2T black 9005	1
	31032351 0022		Cylinder assembly AC166MM (AC51) 2T Gray	1
	31032351 0025		Cylinder assembly AC166MM (AC51) 2T Galvanized	1
	31032351 0039		Cylinder assembly (AC166MM)2.5T Gray	1
	31032351 0057		Cylinder assembly AC166MM(AC51)2.5T Galvanized	1
	31032351 0024		Cylinder assembly ACY166MM(ACY51)2T Gray	1
	31032351 0026		Cylinder assembly ACY166MM(ACY51)2T Galvanized	1
	31032351 0058		Cylinder assembly ACY166MM(ACY51)2T Gray	1
323	95010020 0002	WG-153	Rubber seal15x10x3	1
324	30332351 0001		Thrust plate welding	1
325	91080030 0013	WG-23	Seal ring for axle Y35x45x6	1
326	91080010 0010		O ring -inner 34.52x3.53	1

Hydraulic pump unit

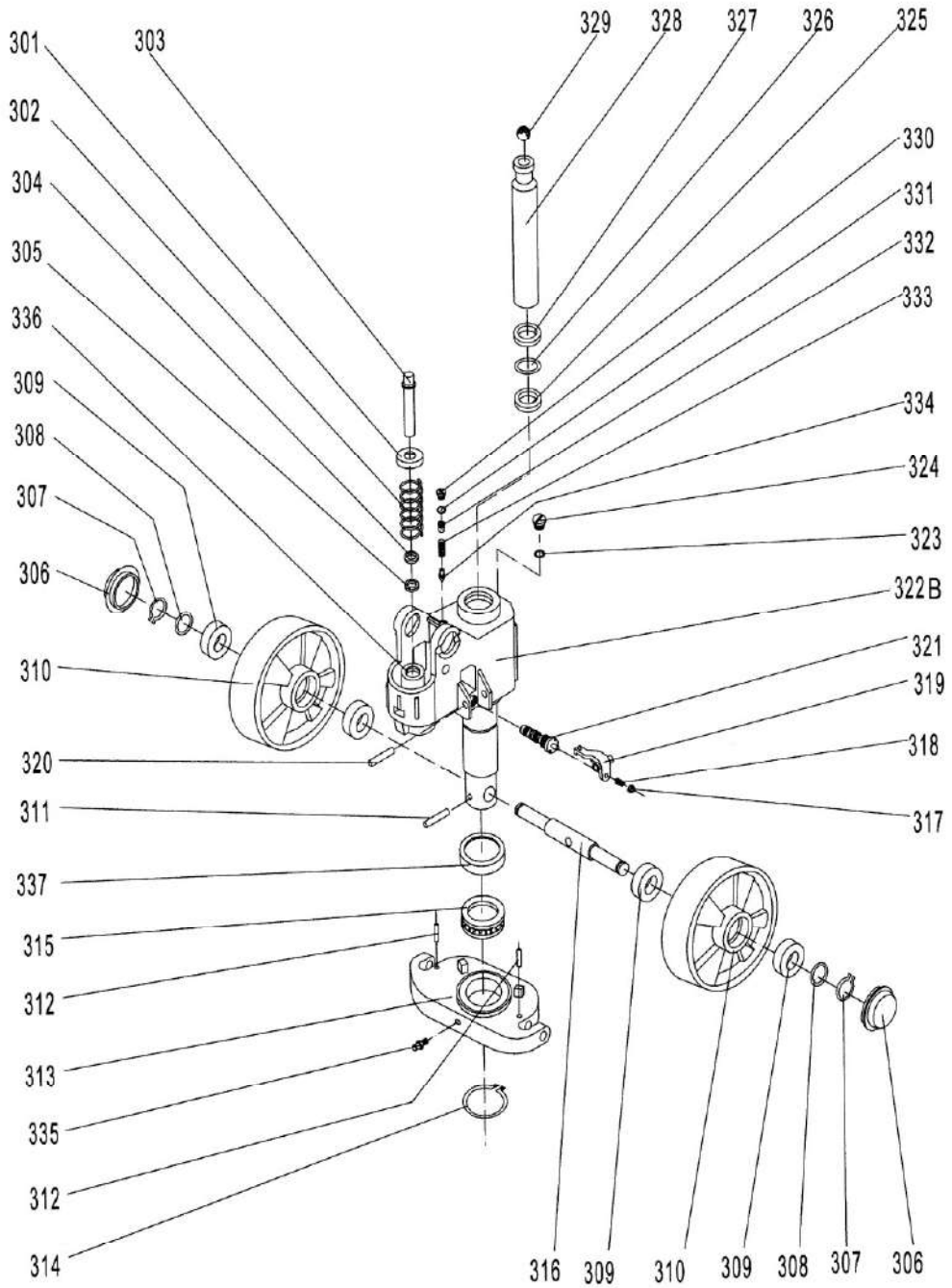

Hydraulic pump unit

327	910800400003		Dust ring FC35x43x5	1
328	300523520007	ACA20.1-8	Piston $\Phi 35 \times 277$	1
329	910701100019		Steel ball GB308-18	1
330	300523520010	T45-109-27	Plug M14x1.5x6	1
331	910800100039		O ring -external 18x2.4	1
332	300523520011	ACA20.1-9	Adjusting screw M12x1.5x18	1
333	940400500060	T45-109-30	Spring $\Phi 7 \times \Phi 3 \times 24.5$	1
334	301023520016	DFA25.2-26	Valve core (safety)	1
335	911200100002		Grease cup JB7940.1-M6x1	1
336	300523520004	ACA20.1-5	Cylinder $\Phi 35.5 \times \Phi 18 \times 60$	1
337	300523520014	ACA20.1-13	Protective cover (bearing) $\Phi 83 \times \Phi 81.4 \times 13$	1

Indicator display unit

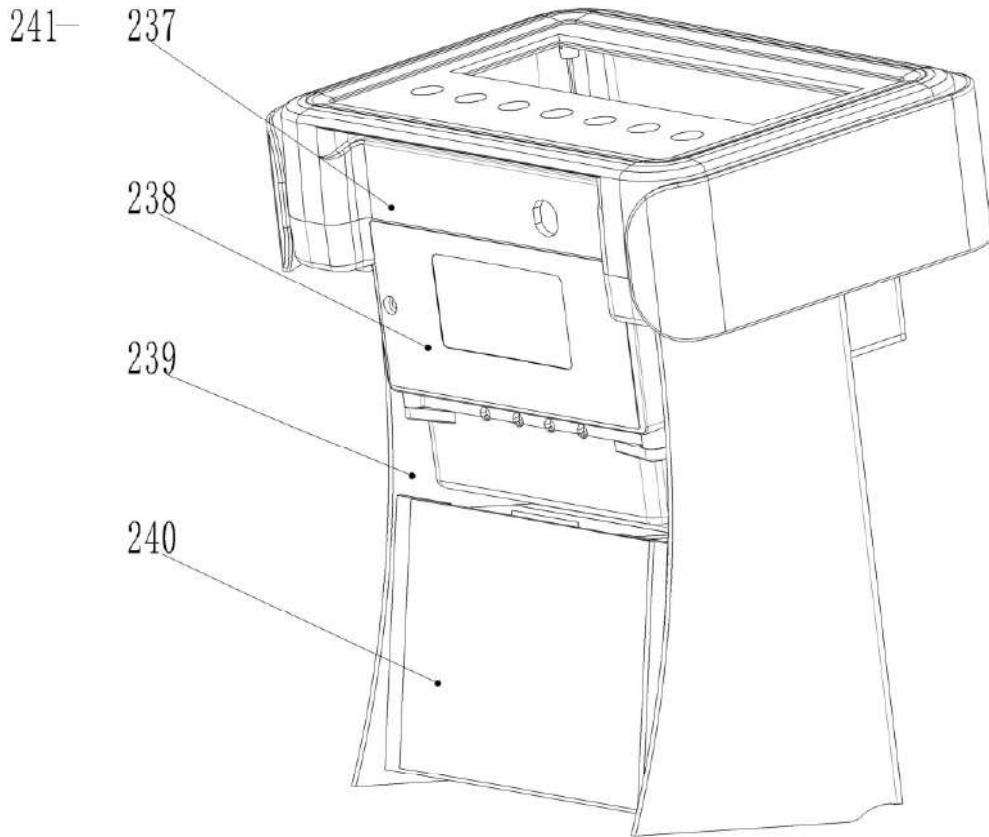

Indicator display unit

No.	Code	DWG No.	Description	Qty.
237	921100100064	(without printer) (EN)	Indicator ESP-300-E	1
	921100100066	(without printer) (CHN)	Indicator ESP-300-C	1
	921100100067	(with printer) (EN)	Indicator ESP-300P-E	1
	921100100068	(with printer) (CHN)	Indicator ESP-300P-C	1
	303333530001	(Suitable for Android Bluetooth 6.0 or above)	Indicator ESP-300P-C (bluetooth)	1
238	920600100109		Battery 6V4.5Ah20HR	1
239	302833510004		Indicator holder welding	1
240	921100100065		Printer LH-EF32-S	1
241	910200200020		Screw GB70.1-M5x8-8.8	4