

EK-X and PXV Technical Data

Vertical Order Picker

EK-X 10

PXV/Li-Ion



EK-X 10 Vertical Order Picker

The new dimension in order picking

This specification sheet to VDI guideline 2198 only gives the technical figures for selected equipment variants.



	1.1	Manufacturer			STILL	STILL	STILL	
Features	1.2	Manufacturer's type designation			EK-X 10 single mast without additional lift	EK-X 10 single mast with additional lift	EK-X 10 telescopic mast with additional lift	
	1.3	Drive			Electric 24 V	Electric 24 V	Electric 24 V	
	1.4	Operator type			Standing/order-picker	Standing/order-picker	Standing/order-picker	
	1.5	Load capacity/load	Q	kg	1000	1000	1000	
	1.6	Load centre	c	mm	400	400	400	
	1.8	Load distance, centre of drive axle to fork	x	mm	180	180	180	
	1.9	Wheel base	y	mm	1270	1260	1415	
	2.1	Service weight (incl. battery)		kg	1564	2069	2711	
	2.2	Axle load, laden	drive end/load end	kg	536/2028	688/2381	1050/2661	
2.3	Axle load, unladen	drive end/load end	kg	1006/558	1168/901	1479/1232		
Tyres/chassis	3.1	Tyres			Polyurethane	Polyurethane	Polyurethane	
	3.2	Tyre size	drive end	mm	Ø 250 x 100	Ø 250 x 100	Ø 250 x 100	
	3.3	Tyre size	load end	mm	Ø 125 x 105	Ø 125 x 105	Ø 150 x 100	
	3.5	Wheels, number (x = driven)	drive end/load end		1x/2	1x/2	1x/2	
	3.7	Track width	load end	b ₁₁	mm	660	850	850
Dimensions	4.2	Height	mast lowered	h ₁	mm	1620	2530	2900
	4.4	Lift		h ₃	mm	1000	1910	4550
	4.5	Height	mast extended	h ₄	mm	2395	4170	6810
	4.7	Height of overhead guard (cab)		h ₆	mm	-	2260	2260
	4.8	Platform height	lowered	h ₇	mm	200	200	200
	4.11	Additional lift		h ₉	mm	-	800	800
	4.14	Platform height	elevated	h ₁₂	mm	1200	2110	4750
	4.14.1	Reach height (h ₁₂ + 1600 mm)	elevated	h ₂₈	mm	2800	3710	6350
	4.15	Height	lowered	h ₁₃	mm	65	65	65
	4.19	Overall length		l ₁	mm	2465	2475	2630
	4.20	Length including fork backs		l ₂	mm	1665	1675	1830
	4.21	Overall width		b ₁ /b ₂	mm	790/790	980/980	980/980
	4.22	Fork dimensions		s/e/l	mm	60/120/800	60/120/800	60/120/800
	4.23	Fork carriage ISO 2328, class/type A, B				Welded forks	Welded forks	Welded forks
	4.24	Fork-carriage width		b ₃	mm	-	740	740
	4.25	Distance between fork-arms	min./max.	b ₅	mm	560	640	640
	4.27	Width across guide rollers		b ₆	mm	-	1375	1375
	4.31	Ground clearance below mast, laden		m ₁	mm	40	40	38
	4.32	Ground clearance, centre of wheelbase		m ₂	mm	40	40	38
	4.34.1	Working aisle width for pallets 1200 x 800 lengthwise		A _{st}	mm	3122	-	-
4.34.2	Working aisle width for pallets 1200 x 800 crosswise		A _{st}	mm	2834	1380	1380	
4.35	Turning radius		W _a	mm	1485	1495	1650	
4.42	Min. transfer aisle width		A _u	mm	2834	2844	2999	
4.44	Clearance, driver compartment entry			mm	460	460	460	
4.45	Overhead clearance, driver compartment, inside			mm	-	2000	2000	
Performance data	5.1	Travel speed	laden/unladen	km/h	9.0/9.0	10.0/10.0	10.0/10.0	
	5.2	Lifting speed	laden/unladen	m/s	0.15/0.19	0.18/0.25	0.22/0.31	
	5.3	Lowering speed	laden/unladen	m/s	0.30/0.24	0.30/0.24	0.30/0.24	
	5.9	Acceleration speed (over 10 m)	laden/unladen	s	7/7	7/7	7/7	
	5.10	Service brake				Regenerative	Regenerative	Regenerative
Electric engine	6.1	Drive motor, rating S2 60 min		kW	3.0	3.0	3.0	
	6.2	Lift motor, rating S3 15 %		kW	3.2 ¹	4.0	7.6	
	6.3	Battery according to DIN 43535			3PzS 420/B	4PzS 560/B	4PzS 560/B	
	6.4	Battery voltage/nominal capacity K ₅		V/Ah	24/420	24/560	24/560	
	6.5	Battery weight (±5 % depending on manufacturer)		kg	385	502	502	
Misc.	10.7	Sound pressure level, operator's position		dB(A)	61	63	69	
		With our VNAP tool we will calculate the technical specifications of the truck with your individual equipment. The calculated speed profiles are based on our floor quality rules. Subject to change without notice. Values can vary ±10%.						

¹ S3 = 10%

EK-X 10 Vertical Order Picker
 Technical Drawings

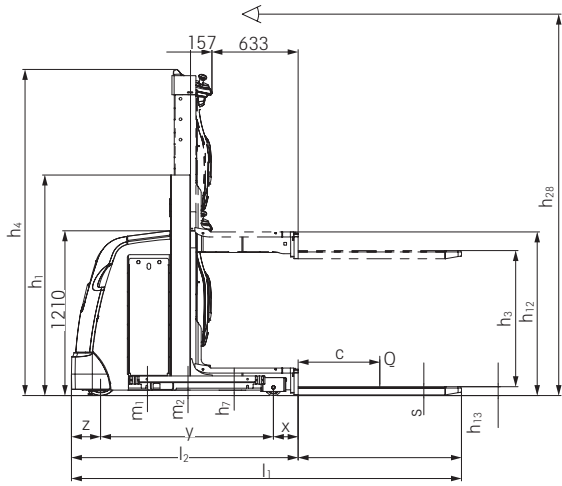

Side view EK-X 10 single mast without auxiliary lift

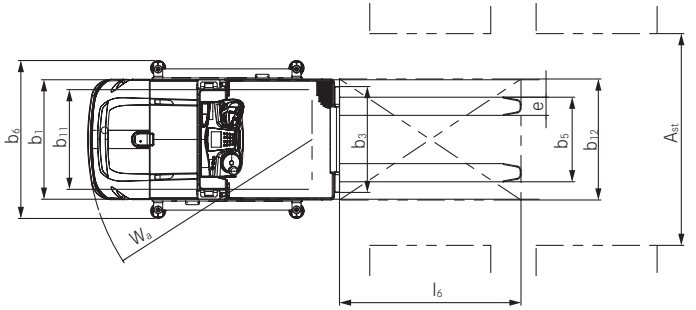

Top view EK-X 10 single mast without auxiliary lift

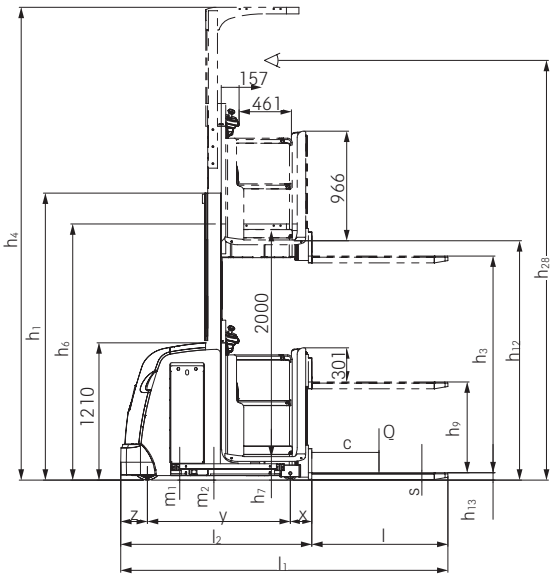

Side view EK-X 10 single mast with auxiliary lift

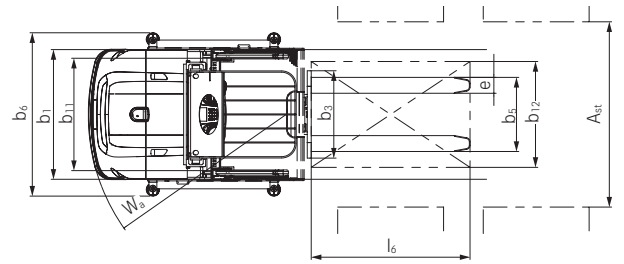

Top view EK-X 10 single mast with auxiliary lift

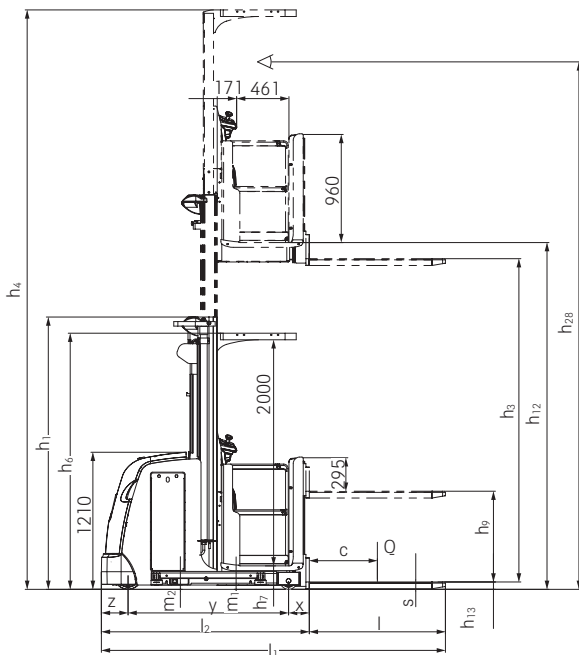

Side view EK-X 10 telescopic mast with auxiliary lift

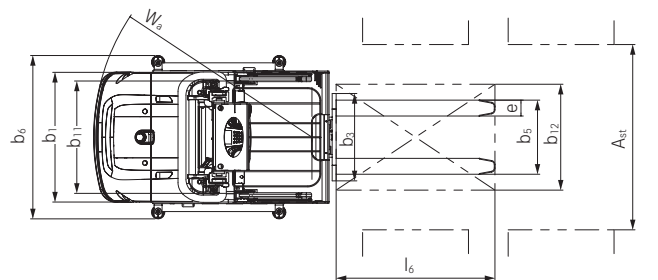

Top view EK-X 10 telescopic lift mast with auxiliary lift

PXV Vertical Order Picker
The new dimension in order picking



		STILL		STILL		STILL		STILL		STILL			
Features	1.1	Manufacturer		STILL		STILL		STILL		STILL			
	1.2	Manufacturer's type designation		PXV M up to 1000 kg telescopic mast with additional lift		PXV M up to 1000 kg telescopic mast with additional lift		PXV M up to 1000 kg telescopic mast with additional lift		PXV up to 1200 kg telescopic mast with additional lift			
	1.3	Drive		Electric 24 V		Electric 48 V		Electric 24 V		Electric 48 V			
	1.4	Operation		Order picker		Order picker		Order picker		Order picker			
	1.5	Load capacity/load		Q	kg	1000	1000	1000	1200	1200	1200		
	1.6	Load centre		c	mm	400	400	600	400	400	400		
	1.8	Load distance		x	mm	353	353	345	345	455	345		
1.9	Wheel base		y	mm	1340	1448	1520	1520	1844	1628			
Weights	2.1	Service weight (incl. battery)		kg		3566	3842	2973	3023	5996	4097		
	2.2	Axle load, laden		drive end/load end		kg	1299/3267	1489/3353	952/3022	1053/3170	2389/4806	1627/3670	
	2.3	Axle load, unladen		drive end/load end		kg	1886/1681	2032/1810	1615/1359	1690/1332	2993/3002	2222/1875	
Tyres/chassis	3.1	Tyres		Polyurethane		Polyurethane		Polyurethane		Polyurethane			
	3.2	Tyre size		drive end		mm	∅ 360/130	∅ 360/130	∅ 360/130	∅ 360/130	∅ 360/130		
	3.3	Tyre size		load end		mm	∅ 180/156	∅ 180/156	∅ 180/156	∅ 180/156	∅ 180/156		
	3.5	Number of wheels (x = driven)		drive end/load end			1x/2	1x/2	1x/2	1x/2	1x/2		
	4.2	Height		mast lowered		h ₁	mm	3900	3900	2250	2250	5400	3400
Dimensions	4.4	Lift		h ₃		mm	6000	6000	2825	2825	12660	5125	
	4.5	Height		mast extended		h ₄	mm	8284	8284	5115	5115	14950	7415
	4.7	Height of overhead guard (cab)		h ₆		mm	2284	2284	2290	2290	2290	2290	
	4.8	Platform height		lowered		h ₇	mm	233	233	240	240	240	240
	4.11	Auxiliary lift		h ₉		mm	800	800	740	740	740	740	
	4.14	Platform height		raised		h ₁₂	mm	6233	6233	3065	3065	12900	5365
	4.14.1	Reach height (h ₁₂ + 1600)		h ₂₈		mm	7833	7833	4665	4665	14500	6965	
	4.15	Height lowered		h ₁₃		mm	65	65	65	65	65	65	
	4.19	Overall length		l ₁		mm	2818	2926	3420	2910	3344	3018	
	4.20	Length including fork backs		l ₂		mm	2018	2126	2220	2110	2544	2218	
	4.21	Overall width		b ₁ /b ₂		mm	1080/1280	1080/1280	880/980	880/980	1080/1580	1080/1580	
	4.22	Fork dimensions		s/e/l		mm	60/120/800	60/120/800	60/120/1200	60/120/800	60/120/800	60/120/800	
	4.23	Fork carriage ISO 2328, class/type A, B				mm	ISO I special fork carriage	ISO I special fork carriage	ISO I special fork carriage	ISO I special fork carriage	ISO I special fork carriage	ISO I special fork carriage	
	4.24	Fork carriage width		b ₃		mm	740	740	660	740	740	740	
	4.25	Overall fork width		min./max.		b ₅	mm	640/640	640/640	560/560	640/640	640/640	640/640
	4.27	Width across guide rollers		b ₆		mm	1375	1375	1075	1375	2000	1995	
	4.31	Ground clearance below mast, laden		m ₁		mm	50	50	50	50	50	50	
	4.32	Ground clearance, centre of wheel base		m ₂		mm	50	50	50	50	50	50	
	4.34	Working aisle width		A _{st}		mm	1380	1380	1080	1380	2100	2000	
	4.35	Turning radius		W _a		mm	1801	1902	1951	1765	2190	1999	
4.42	Min. transfer aisle width		A _u		mm	3301	3402	3747	3258	3781	3492		
Performance data	5.1	Travel speed		laden/unladen		km/h	10.0/10.0	10.0/10.0	10.0/10.0	11.0/11.0	13.0/13.0	13.0/13.0	
	5.2	Lifting speed		laden/unladen		m/s	0.26/0.30	0.50/0.50	0.24/0.30	0.36/0.36	0.40/0.40	0.49/0.50	
	5.3	Lowering speed		laden/unladen		m/s	0.28/0.28	0.45/0.45	0.28/0.28	0.32/0.32	0.45/0.45	0.45/0.45	
	5.9	Acceleration speed (to 10 m)		laden/unladen		s	6/6	6/6	7/7	7/7	6/6	6/6	
	5.10	Service brake					Regenerative	Regenerative	Regenerative	Regenerative	Regenerative	Regenerative	
Electric motor	6.1	Drive motor, rating S2 = 60 min				kW	4.0	6.5	4.0	6.5	6.5		
	6.2	Lift motor, rating S3 = 15%				kW	7.6	13.0 ¹	7.6	13.0 ¹	13.0 ¹		
	6.3	Battery according to DIN 43531/35/36 A, B, C, no					6PzS 840 A	4 PzS 560 A	6 PzS 840 A	3 PzS 420 A	6 PzS 930 A	4 PzS 560 A	
	6.4	Battery voltage/nominal capacity K _s				V/Ah	24/840	48/560	24/840	48/420	48/930	48/560	
	6.5	Battery weight (±5% depending on manufacturer)				kg	687	933	687	739	1309	933	
Misc.	8.1	Transmission control					Microprocessor	Microprocessor	Microprocessor	Microprocessor	Microprocessor		
	8.4	Sound pressure level, operator's position				dB(A)	61	61	61	61	61		

Values can vary by +/-10%. The calculated driver profiles are based on our floor quality rules. Subject to technical changes.

¹ S3 = 20%

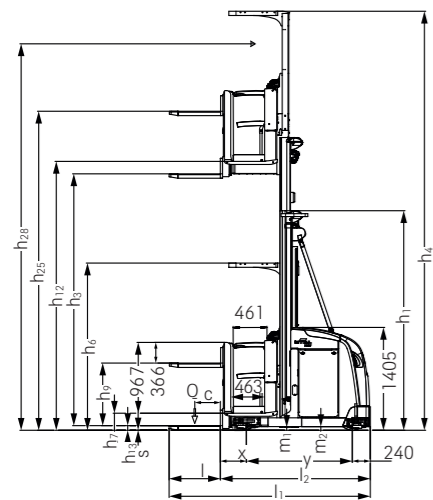

Side view PXV M up to 1000 kg with telescopic mast

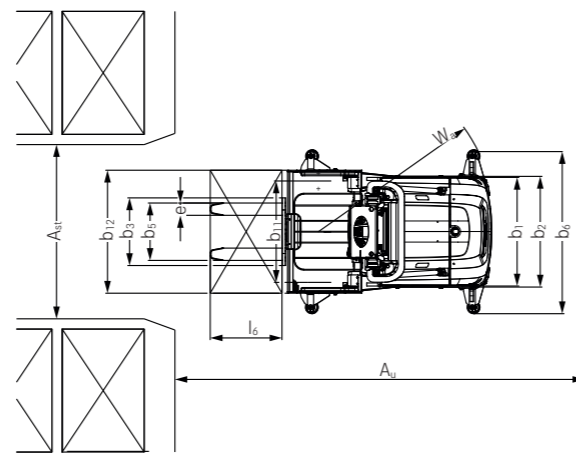

Top view PXV M up to 1000 kg with telescopic mast

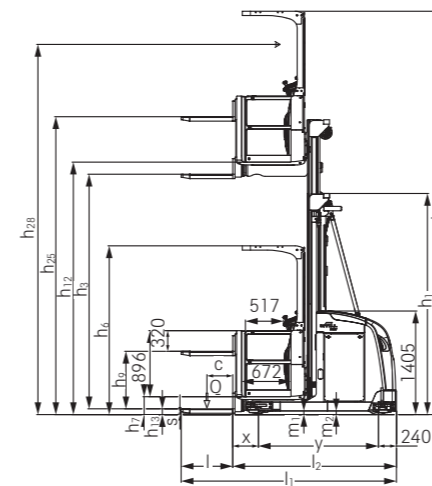

Side view PXV up to 1200 kg with telescopic mast

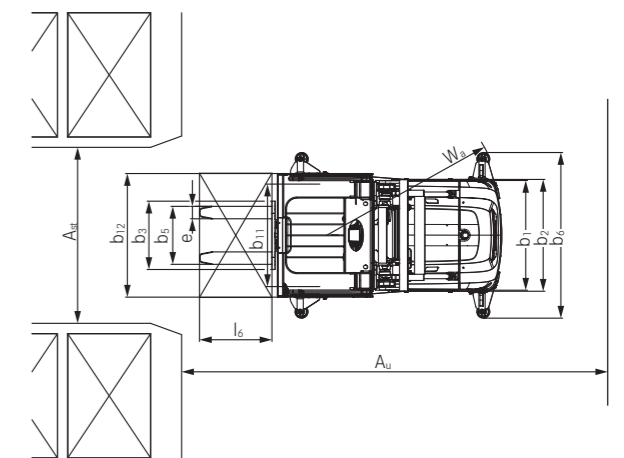

Top view PXV up to 1200 kg with telescopic mast

EK-X 10 and PXV Vertical Order Picker Mast Tables



EK-X 10 single mast with additional lift	Height, mast lowered	h_1	mm	1620	2120	2530					
	Total lift above floor	$h_{25} (h_3 + h_9 + h_{13})$	mm	1865	2365	2775					
	Total lift	$h_{24} (h_3 + h_9)$	mm	1800	2300	2710					
	Nominal lift	h_3	mm	1000	1500	1910					
	Height, lowered	h_{13}	mm	65	65	65					
	Additional lift	h_9	mm	800	800	800					
	Stand height, elevated	$h_{12} (h_3 + h_7)$	mm	1200	1700	2110					
	Picking height	$h_{28} (h_{12} + 1,600)$	mm	2800	3300	3710					
	Height, mast extended	h_4	mm	2395	3760	4170					
EK-X 10 telescopic mast with additional lift	Height, mast lowered	h_1	mm	2400	2900						
	Total lift above floor	$h_{25} (h_3 + h_9 + h_{13})$	mm	4415	5415						
	Total lift	$h_{24} (h_3 + h_9)$	mm	4350	5350						
	Nominal lift	h_3	mm	3550	4550						
	Height, lowered	h_{13}	mm	65	65						
	Additional lift	h_9	mm	800	800						
	Stand height, elevated	$h_{12} (h_3 + h_7)$	mm	3750	4750						
	Picking height	$h_{28} (h_{12} + 1,600)$	mm	5350	6350						
	Height, mast extended	h_4	mm	5810	6810						
PXV M up to 1000 kg telescopic mast	Height, mast lowered	h_1	mm	2250	2400	2900	3400	3900			
	Total lift above floor	$h_{25} (h_3 + h_9 + h_{13})$	mm	4115	4415	5415	5865	6865			
	Total lift	$h_{24} (h_3 + h_9)$	mm	4050	4350	5350	5800	6800			
	Nominal lift	h_3	mm	3250	3550	4550	5000	6000			
	Height, lowered	h_{13}	mm	65	65	65	65	65			
	Additional lift	h_9	mm	800	800	800	800	800			
	Stand height, elevated	$h_{12} (h_3 + h_7)$	mm	3483	3783	4783	5233	6233			
	Picking height	$h_{28} (h_{12} + 1600)$	mm	5083	5383	6383	6833	7833			
	Height, mast extended	h_4	mm	5534	5834	6834	7284	8284			
PXV up to 1200 kg telescopic mast - Chassis widths $b_1 = 880$ mm	Height, mast lowered	h_1	mm	2250	2450	2900	3400	3900	4400		
	Total lift above floor	$h_{25} (h_3 + h_9 + h_{13})$	mm	3630	4030	4930	5930	6530	7530		
	Total lift	$h_{24} (h_3 + h_9)$	mm	3565	3965	4865	5865	6465	7465		
	Nominal lift	h_3	mm	2825	3225	4125	5125	5725	6725		
	Height, lowered	h_{13}	mm	65	65	65	65	65	65		
	Additional lift	h_9	mm	740	740	740	740	740	740		
	Stand height, elevated	$h_{12} (h_3 + h_7)$	mm	3065	4025	4925	5925	6525	7525		
	Picking height	$h_{28} (h_{12} + 1600)$	mm	4665	5065	5965	6965	7565	8565		
	Height, mast extended	h_4	mm	5115	5515	6415	7415	8015	9015		
PXV up to 1200 kg telescopic mast - Chassis widths $b_1 = 1080$ mm	Height, mast lowered	h_1	mm	2250	2450	2900	3400	3900	4400	4900	5400
	Total lift above floor	$h_{25} (h_3 + h_9 + h_{13})$	mm	3630	4030	4930	5930	6530	7530	8530	9330
	Total lift	$h_{24} (h_3 + h_9)$	mm	3565	3965	4865	5865	6465	7465	8465	9265
	Nominal lift	h_3	mm	2825	3225	4125	5125	5725	6725	7725	8525
	Height, lowered	h_{13}	mm	65	65	65	65	65	65	65	65
	Additional lift	h_9	mm	740	740	740	740	740	740	740	740
	Stand height, elevated	$h_{12} (h_3 + h_7)$	mm	3065	4025	4925	5925	6525	7525	8525	9325
	Picking height	$h_{28} (h_{12} + 1600)$	mm	4665	5065	5965	6965	7565	8565	9565	10365
	Height, mast extended	h_4	mm	5115	5515	6415	7415	8015	9015	10015	10815
PXV up to 1200 kg triplex mast - without free lift	Height, mast lowered	h_1	mm	3300	3800	4350	4800	5400			
	Total lift above floor	$h_{25} (h_3 + h_9 + h_{13})$	mm	7965	9465	10765	11965	13465			
	Total lift	$h_{24} (h_3 + h_9)$	mm	7900	9400	10700	11900	13400			
	Nominal lift	h_3	mm	7160	8660	9960	11160	12660			
	Height, lowered	h_{13}	mm	65	65	65	65	65			
	Additional lift	h_9	mm	740	740	740	740	740			
	Stand height, elevated	$h_{12} (h_3 + h_7)$	mm	7400	8900	10200	11400	12900			
	Picking height	$h_{28} (h_{12} + 1600)$	mm	9000	10500	11800	13000	14500			
	Height, mast extended	h_4	mm	9490	10990	12290	13490	14990			
PXV up to 1200 kg triplex mast - with free lift	Height, mast lowered	h_1	mm	2250	2450	2900	3200	3700	4200	4700	
	Free lift	h_2	mm	1600	1800	2250	2550	3050	3550	4050	
	Total lift above floor	$h_{25} (h_3 + h_9 + h_{13})$	mm	5215	5815	7165	7965	9465	10765	11965	
	Total lift	$h_{24} (h_3 + h_9)$	mm	5150	5750	7100	7900	9400	10700	11900	
	Nominal lift	h_3	mm	4410	5010	6360	7160	8660	9960	11160	
	Height, lowered	h_{13}	mm	65	65	65	65	65	65	65	
	Additional lift	h_9	mm	740	740	740	740	740	740	740	
	Stand height, elevated	$h_{12} (h_3 + h_7)$	mm	4650	5250	6600	7400	8900	10200	1140	
	Picking height	$h_{28} (h_{12} + 1600)$	mm	6250	6850	8200	9000	10500	11800	13000	
Height, mast extended	h_4	mm	6700	7300	8650	9450	10950	12250	13450		



Reach height
up to 14.5 metres

PXV
Vertical order picker
with telescopic mast
up to 1,200 kg

Reach height
up to 7.8 metres

PXV M
Vertical order picker
with telescopic mast
up to 1,000 kg

Reach height
up to 6.3 metres

EK-X 10
Vertical order picker
with telescopic mast
up to 1,000 kg



EK-X 10 Vertical Order Picker
Detailed Photos



Efficient truck utilisation thanks to optional two-sided operation

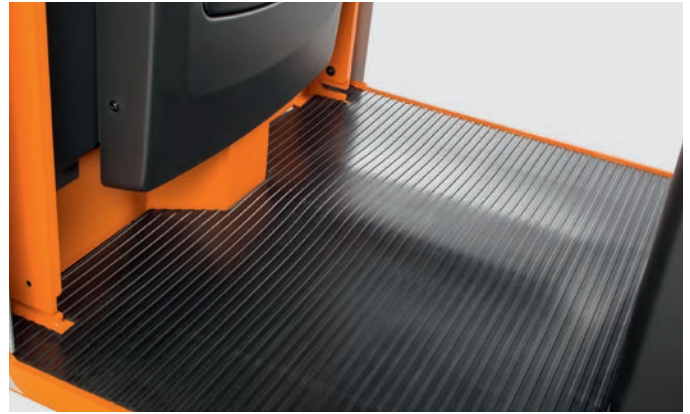

Shock-protected floor with integrated drive switch for more driving comfort without obstacles inside the operator's cab



Accessible pallet with guard as option for ergonomic order picking of heavy and bulky goods

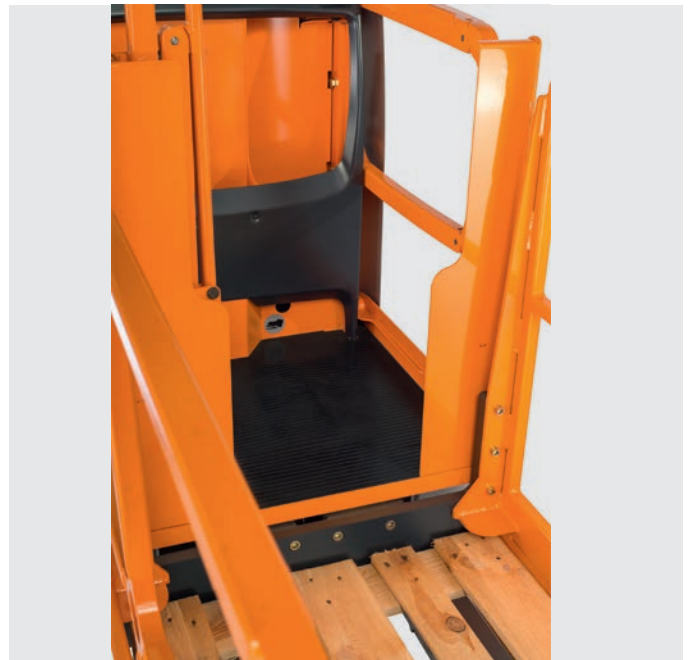

Simple and safe pallet entry with additional barriers in load direction



Tilting bar for ergonomic order picking to the last article on the pallet



Optional operation with data terminal, printer and scanner

PXV Vertical Order Picker Detailed Photos



Maximum safety and flexibility when operating the truck thanks to display and control elements that can be positioned on the load end or mast side to suit requirements

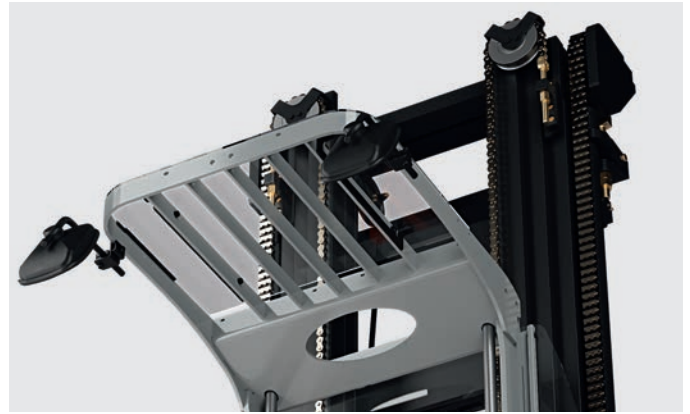

Two rear-view mirrors ensure an optimum view of the surroundings at all times



Easy access to goods no matter how far back thanks to the optional lateral tilting barriers on the operator's cab



Safety is key: with the optional protective cage on the accessible pallet, the operator is protected even when moving around on the pallet at height



Plenty of space for equipment and materials thanks to the intelligent storage concept



Safety and efficiency with everything in view: the mast ensures a clear view in the drive direction at all times



Fast charging for optimum availability: direct charging access on the PXV is key and makes handling the charging connector a lot easier for all operators

PXV Vertical Order Picker iGo pilot

The right system for any customer requirement: STILL iGo pilot can determine its position via RFID tags as well as barcode labels

Customised configuration: the system can be individually adapted to any conceivable very narrow-aisle warehouse

Optimal working conditions: doing away with search processes and errant runs relieves the burden on the operator and enables quick incorporation of new employees

iGo pilot

STILL iGo pilot - Performance profile at a glance

The iGo pilot navigation and iGo pilot safety functions link the specific warehouse topography to the trucks operating within.

The iGo pilot navigation interface communicates with the warehouse management system and combines the warehouse processes into an intelligent whole. As a result, the truck knows the next pick location to reach in the high pallet rack, thus unburdening the operator. When the operator accepts the next order, the truck determines the optimal route to this location and the operator only needs to control the device through one control lever. Thanks to iGo pilot safety assistance

and warning systems, which can be individually preconfigured to any warehouse, the truck proactively adapts to its route as well as to local conditions and potential hazards. Once the truck has reached its target position with iGo pilot navigation, it ensures that the vehicle stops at exactly the right position, both horizontally and vertically. Once the picking task has been completed, the data is sent back to the warehouse management system in order to prevent order-picking errors. The result is a significant increase in handling capacity as well as increased safety thanks to networked agility.



Easy to use: destinations can be entered via scanner, terminal or online from the warehouse management system, and the process is started with just one movement of the drive lever

Supreme productivity: the truck automatically navigates to its destination along the ideal route, regardless of the experience and knowledge of the operator

Smart precision: the truck moves to exactly the right pallet position, with the possibility of preventing fork movements when not required

iGo pilot navigation

iGo pilot navigation leads the operator in their very narrow aisle truck along the ideal route to the desired position. This is possible thanks to a three-dimensional shelving plan that maps the specific topography of the warehouse. By comparing against this map stored in the system, the truck detects its current location in the aisle as well as its position. iGo pilot navigation adjusts to the activities of storage, retrieval and

order-picking. As soon as an order comes in, the system determines the optimal horizontal and vertical route to the desired location. By means of an optical display, the operator can see his current position in relation to the destination. He can only move his truck in the direction indicated. If he is in the wrong aisle, the display will flag this up to them.

Thanks to the variety of safety functions, the driver assistant protects goods, shelves, building equipment and the truck from damage

Always ready for action: reduced downtime by avoiding impact damage and the resulting repairs

Through a simplified workflow, drivers can fully concentrate on their core activity order-picking

iGo pilot safety

If iGo pilot safety is installed, the operational safety and handling capacity of STILL very narrow aisle trucks are both significantly improved. Moreover, areas in the very narrow aisle warehouse where special safety regulations apply are defined in advance. A three-dimensional map of these areas is stored in the truck. This mapping is provided by STILL. This allows to masterfully handle obstacles in

the shelving aisle, required braking distances at the end of aisles and height restrictions during everyday operations. In addition, the truck constantly identifies its current position using the map. During its journey, the truck detects every warehouse aisle and its specific conditions and adapts to these without the operator having to intervene. The system always follows the predefined safety rules.

EK-X 10 and PXV Vertical Order Picker Modularity down to the smallest bolt

Truck configurations suitable for every warehouse and all goods:
Millions of combination options. We determine which vertical order picker is suitable for you using the STILL configuration software. Based

on the dimensions of your warehouse, the loads to be transported, the necessary movement of goods and potential growth in the future, we design the perfect forklift truck with you, for you.

Cabin variants

Combined and comfort cabins for more freedom of movement

Batteries

24 V or 48 V,
Lead-acid or Li-Ion

Various mast variants

for reach heights of up to
14.5 metres



EK-X 10 and PXV Vertical Order Picker

The new dimension in order picking

Precise and safe working even at high speeds thanks to the clear view afforded by the mast

Comfortable, variable and safe standing position in the spacious operator's cab with shock-absorbing floor

Convenient access to goods thanks to tilting barriers that reduce distance to rack



EK-X 10

Making order picking child's play: the EK-X 10 vertical order picker is the perfect combination of efficiency and ergonomics. It performs impressively in both wide and narrow-aisle warehouses with its excellent handling capacity, optimum safety and ergonomic comfort. The compact warehouse aid can lift up to 1,000 kg up to a height of 6.3 metres. The clear line of sight afforded by the mast ensures operators have the best view for high-precision, safe work even at pace. When it comes to safety and ergonomics, the spacious operator's

cab delivers: lots of freedom to move, variable storage and a shock-absorbing floor ensure maximum comfort, while tilting side barriers reduce the distance between the order picker and the rack and enable the ergonomic retrieval of goods – no matter how far back. Selection of equipment variants – e. g. single or telescopic mast, with or without additional lift – and individual configuration options make the EK-X 10 a flexible partner for the myriad challenges that may arise in a warehouse.

Excellent space and storage efficiency: order picking height of up to 14.5 metres

Simultaneous lifting and lowering of main and additional lift

Easy touch: fingertip operation for easy lowering of the additional lift while order picking

Perfectly configured to meet any challenge thanks to the modular system



PXV

It is the king of order picking and impresses with its exceptional goods handling and maximum reach heights, as well as offering a whole new level of safety and ergonomics. Whether put to use in wide or narrow-aisle warehouses, no other order picker uses space and time as cleverly as the PXV vertical order picker. With an order picking height of 14.5 metres, the 'large' variant – which has a load capacity of 1,200 kg – can reach even the highest shelves. Its little brother meanwhile can work at reach heights of up to 7.8 metres with a load capacity of 1,000 kg. In both versions, smooth mast transition journeys not only ensure comfortable working but also impressive goods handling.

The PXV sets new standards when it comes to user friendliness and ergonomics, too. The operator is supported by intelligent assistance systems, such as the STILL OptiSpeed system which ensures the highest possible speed without jeopardising driving safety. It also offers an excellent field of vision in the load and drive direction, plus a spacious, shock-absorbing operator's cab with tilting barriers for easy access to goods. Additional assistance systems for even greater safety and efficiency plus numerous equipment variants can also be selected individually and make the PXV the perfect, tailor-made companion for every warehouse. It's the new dimension in order picking.



Simply easy

- Particularly sensitive operation and continuous control of lifting speed thanks to the latest proportional valve technology
- Intuitive control through the steering wheel or steering knob makes it easy for the operator to use all functions, customised to their needs
- Optimum user comfort provided by the spacious shock-protected stand-on platform with integrated presence switch
- Quick and easy charging at any time thanks to optional opportunity charging in lithium-ion variants



Simply powerful

- Reliable availability with powerful, low-maintenance AC drives for driving and lifting
- Efficient and powerful performance for every customer requirement thanks to individually configurable driving and lifting speeds
- Unrivalled space utilisation with a reach height of up to 14.5 metres
- Fast lifting and lowering speed thanks to mast without free lift and without mast transition journeys
- Optimum handling performance thanks to smart OptiSpeed assistance system in a range of customised versions



Simply safe

- Operating safety guaranteed with innovative iGo pilot safety aisle safety assistant
- Optional tilting barriers allow reduced distance between truck and rack – for quick, safe and ergonomic order picking
- Safe, comfortable and healthy operator's cab with optional knee and support cushions
- Optimum truck and operation safety with electronic monitoring of battery locking



Simply flexible

- Individually configurable for a wide range of uses thanks to modular truck concept
- Accessible pallet allows the operator to enter the pallet to pick bulky and heavy goods
- Flexible operator's cab design using a mounting bar system for simple integration of tools (optional)



Simply connected

- Maximum handling with intelligent STILL iGo pilot navigation assistance system and semi-automated bay approach
- Simple connection to warehouse management system for optimum control of goods flow with STILL iGo pilot interface
- Optimum truck safety, access protection and damage minimisation with STILL FleetManager 4.x

Simply Efficient



EK-X 10 and PXV Vertical Order Picker Equipment Variants



		EK-X 10 b ₁ = 790 mm	EK-X 10 b ₁ = 980 mm	PXV M up to 1000 kg b ₁ = 1080-1580 mm	PXV up to 1200 kg b ₁ = 880-1580 mm
Operator's cab	Operator's cab for more freedom of movement	○	○	○	—
	Overhead guard height 2000/2200 mm	○	○	○	○
	Control panel on mast side/load end with steering knob/steering wheel	○	○	○	○
	Control panel with continuous electric height adjustment	—	—	—	○
	LED display	●	●	●	—
	Tilting barriers to reduce distance to rack	○	○	○	○
	Knee cushion on picking platform with integrated storage compartment	○	○	○	○
	Fold-out and cushioned lean-to support mounted on mast side	○	○	○	○
	LED light for operator's cab	○	○	○	○
	LED headlights to illuminate the shelves	○	○	○	○
	Flexible bar system for workplace configuration (mast side/load end)	○	○	○	○
	Power socket 12 V / 2 A	○	○	○	○
	Electrical and mechanical operation of data terminal/printer/scanner	○	○	○	○
	Operator's cab with damping of shocks and vibrations	●	●	●	●
	Various cab widths	○	○	○	○
	Very low step height for easy entry and exit	●	●	●	●
Fan on the overhead guard	○	○	○	○	
Cover for the overhead guard	○	○	○	○	
Assistance systems	Steering angle-dependent continuous speed reduction for more safety	●	●	●	—
	OptiSpeed 3.0: lift height-dependent speed adjustment	—	—	●	●
	OptiSpeed 3.3: weight and load detection for speed optimisation	—	—	—	○
	STILL iGo pilot navigation: semi-automatic bay approach	—	—	—	○
Drives	Regenerative electric braking through the drive motor for optimal use of energy	●	●	●	●
Safety	STILL iGo pilot safety: tailor-made safety and flexibility in narrow aisles	—	—	—	○
	FleetManager: access authorisation, shock detection, reports	○	○	○	○
	Rescue alarm for atypical operator actions to attract attention	○	○	○	○
	Automatic braking at the aisle end with PSS, RFID tags or magnetic switch	—	○	○	○
	PSS/preparation of PSS	—	○	○	○
	Rail guide with entrance rollers	○	○	○	○
	Inductive forced guidance with automatic loop finder	—	○	○	○
	Increased residual load capacity for heavy loads at large heights	—	—	○	○
	STILL Safety Light	○	○	○	○
	Adjustable lifting override and lowering stop	○	○	○	○
	Contact-free collision protection on the overhead guard	○	○	○	○
	Acoustic warning signal when driving in the direction of the load and/or drive	○	○	○	○
	Anti-static design	○	○	○	○
Access via key switch, PIN code, chip or card	○	○	○	○	
Battery	Roller track for lateral battery change	○	○	○	○
	Battery change with forklift truck	—	—	●	●
	Battery change with crane	●	●	—	—
	Various battery compartments for 24 V batteries	○	○	○	○
	Various battery compartments for 48 V batteries	—	—	○	○
	Various battery compartments for 48 V lithium-ion batteries	—	—	○	○
	Li-Ion-ready for 48 V battery compartment	—	—	○	○
Fast charging access	—	—	○	○	
Additional accessories	Cold store variant for temperatures of up to -30 °C	○	○	○	○
	Accessible pallet, including protective cage	○	○	○	○
	Additional lift	○	○	○	○
	Welded or FEM fork carriage	○	○	○	○

● Standard ○ Option — Not available