

C 15/18/20s

LPG engine

Pneumatic or Superelastic tyres

1500 kg 1800 kg 2000 kg

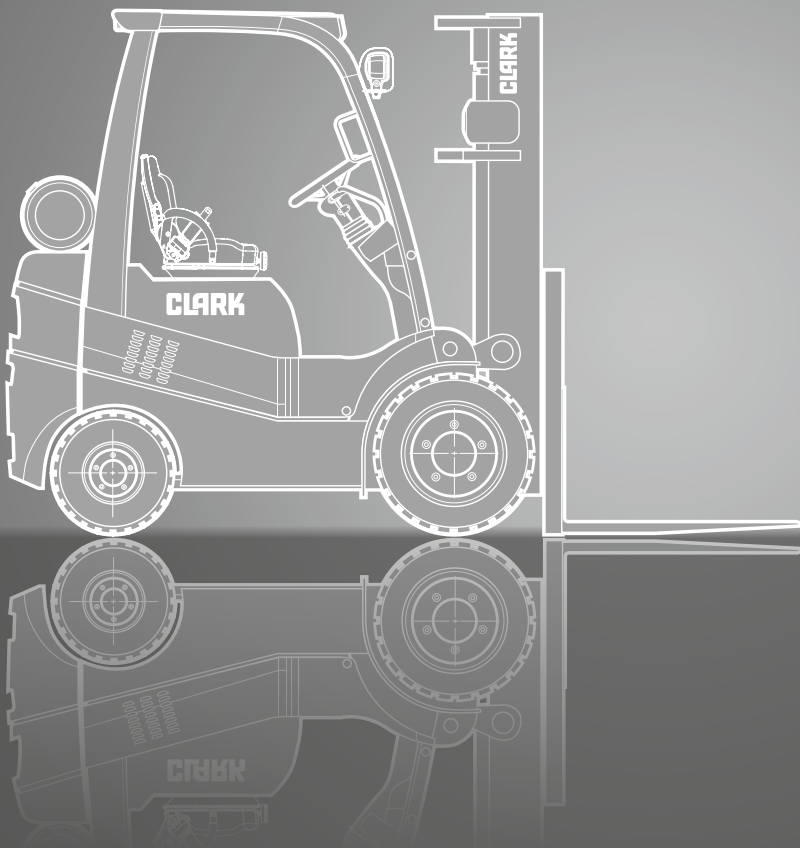

DIMENSIONS

C15/18/20s

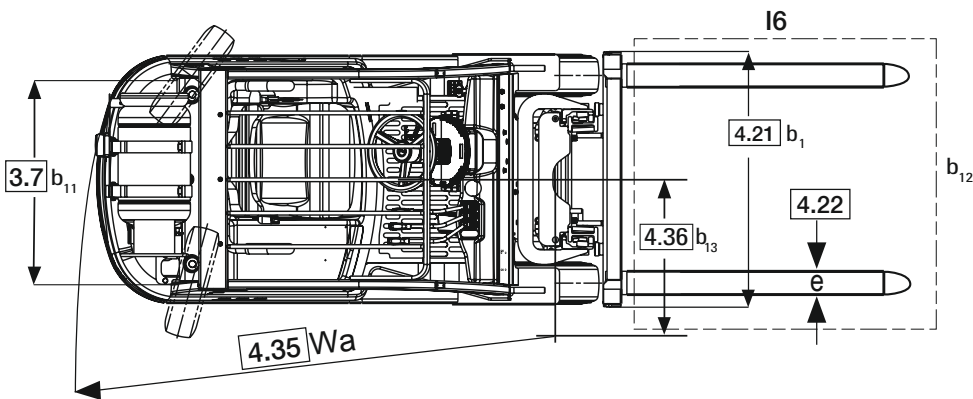
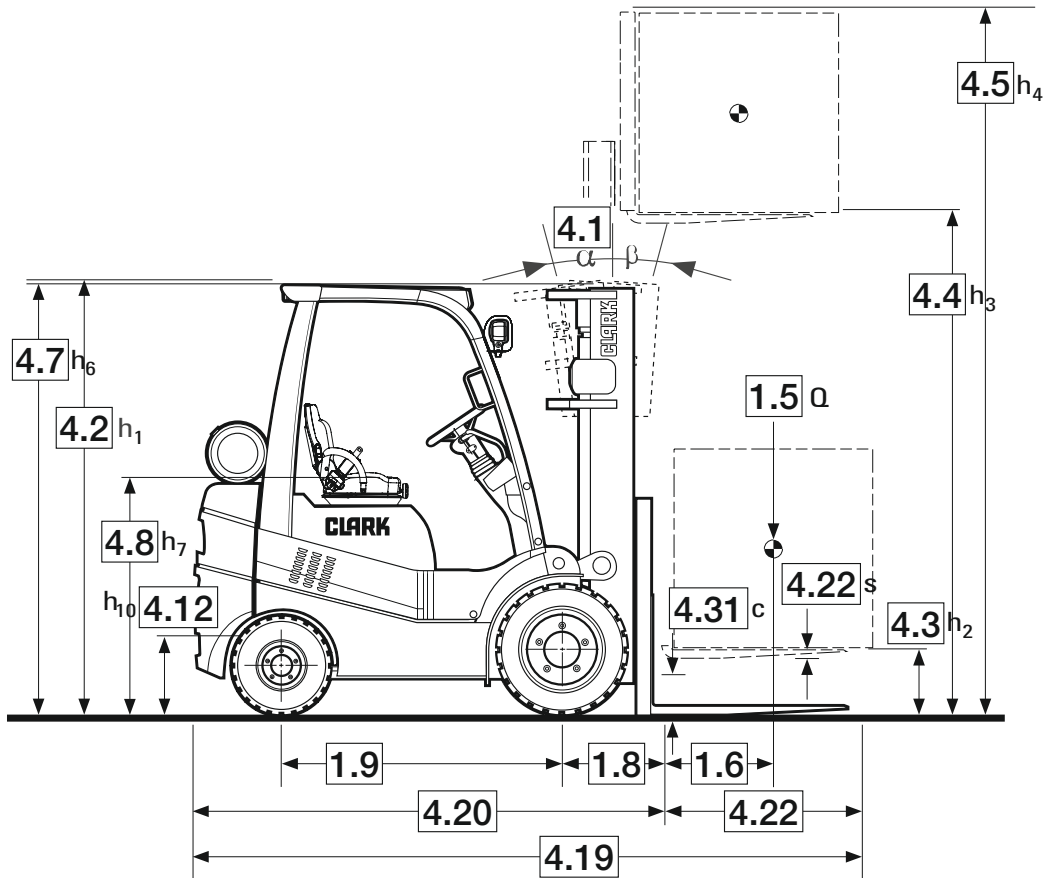

$$A_{st} = Wa + x + \frac{l_6}{2} + a$$

applies only if $\frac{b_{12}}{2} < b_{13}$

$$A_{st} = Wa + \sqrt{(l_6 + x)^2 + \left(\frac{b_{12}}{2} - b_{13}\right)^2} + a$$

applies only if $\frac{b_{12}}{2} \geq b_{13}$

$a = 200$

For corresponding data see Specification Chart.

GENERAL DATA

Truck Capacities Capacity at different load centres

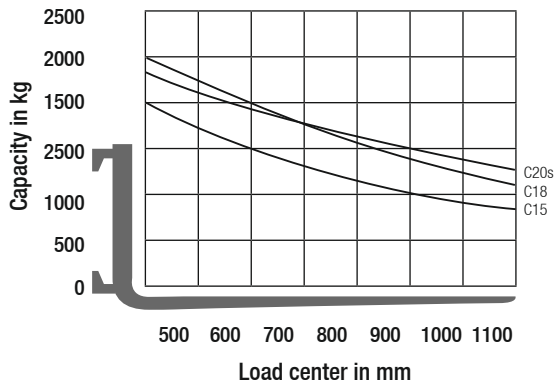

NOTE:

The listed capacities are valid only for the standard upright in vertical position with standard fork carriage and standard forks, up to max. lifting height of 3285mm. The centre of gravity of the load may be displaced by max. 100mm against the longitudinal centre line of the truck. Load centre is determined from top and front face of forks. The values are based on a 1000mm, cube load configuration with the centre of gravity at the true centre of the cube. With upright tilted forward lower capacity values are valid. Attachments, longer forks, exceptional load dimensions and higher lifting heights may reduce the capacity.

Upright table C15/18/20s

	Maximum fork height (h3)	Mast lowered (h1)	Mast extended (h4)		Free lift (h2)	
			with load backrest	without load backrest	with load backrest	without load backrest
	mm	mm	mm	mm	mm	mm
Standard	2265	1730	3489	2899	110	110
	2545	1870	3769	3179		
	2795	1995	4019	3429		
	3085	2140	4309	3719		
	3285	2240	4509	3919		
	3640	2417	4863	4273		
	4070	2690	5293	4703		
	4365	2890	5589	4999		
	4655	3085	5877	5287		
	5145	3415	6365	5775		
Triplex	3970	1870	5192	4603	649	1238
	4345	1995	5567	4978	774	1363
	4780	2140	6002	5413	919	1508
	5185	2290	6406	5817	1069	1658
	5400	2380	6620	6031	1159	1748
	5565	2450	6786	6197	1229	1818
	5720	2515	6936	6347	1294	1883
	6015	2640	7238	6649	1419	2008
	6470	2830	7690	7101	1609	2198
	7075	3085	8296	7707	1864	2453
Hi-Lo	2925	1995	4147	3542	774	1379
	3215	2140	4436	3831	919	1524
	3515	2290	4736	4131	1069	1674
	3695	2380	4916	4311	1159	1764
	3810	2450	5033	4428	1229	1834

Performance may vary +5% and -10% due to motor and system efficiency tolerance. The performance shown represents nominal values which may be obtained under typical operating conditions of a machine. CLARK products and specifications are subject to change without notice.

SPECIFICATIONS

Product Specifications acc. to VDI 2198

	1.1 Manufacturer (Abbreviation)	CLARK	CLARK	CLARK
Specifications	1.2 Manufacturer's designation	C15L	C18L	C20sL
	1.3 Drive unit Diesel, LPG	LPG	LPG	LPG
	1.4 Operator type stand on/driver seated	Driver seated	Driver seated	Driver seated
	1.5 Load capacity/rated load Q (kg)	1500	1800	2000
	1.6 Load centre distance c (mm)	500	500	500
	1.8 Load centre distance, centre of drive axle to fork face x (mm)	392	392	392
	1.9 Wheelbase y (mm)	1400	1400	1400
Weight	2.1 Service weight kg	2785	3009	3156
	2.2 Axle loading, laden front/rear kg	3733/552	4166/643	4449/707
	2.3 Axle loading, unladen front/rear kg	1277/1508	1219/1790	1175/1981
Tyres, Chassis	3.1 Tyre type, P = pneumatic, SE = superelastic *1	P	P	P
	3.2 Tyre size, front	6.50 x 10 - 12PR	6.50 x 10 - 12PR	6.50 x 10 - 12PR
	3.3 Tyre size, rear	5.00 x 8 - 10PR	5.00 x 8 - 10PR	5.00 x 8 - 10PR
	3.5 Wheels, number front/rear (x = drive wheels)	2x/2	2x/2	2x/2
	3.6 Tread, front b10 (mm)	890	890	890
	3.7 Tread, rear b11 (mm)	890	890	890
	Dimensions	4.1 Tilt of upright/fork carriage, α/β Grad	8/8	8/8
4.2 Height, upright lowered h1 (mm)		2240	2240	2240
4.3 Freelift h2 (mm)		110	110	110
4.4 Lift height *2 h3 (mm)		3285	3285	3285
4.5 Height, upright extended (with LBR) h4 (mm)		4509	4509	4509
4.7 Height overheadguard Std/(Cabin) *5 h6 (mm)		2120 (2135)	2120 (2135)	2120 (2135)
4.8 Seat height h7 (mm)		1100	1100	1100
4.12 Coupling height h10 (mm)		310	310	310
4.19 Overall length l1 (mm)		3271	3316	3358
4.20 Length to face of forks l2 (mm)		2201	2246	2288
4.21 Width b1 (mm)		1070	1070	1070
4.22 Fork dimensions s • e • l (mm)		40 x 100 x 1070	40 x 100 x 1070	40 x 100 x 1070
4.23 Fork carriage DIN 15173, A, B		CLASS IIA	CLASS IIA	CLASS IIA
4.24 Fork carriage width b3 (mm)		940	940	940
4.31 Ground clearance minimum m1 (mm)		120	120	120
4.32 Ground clearance centre of wheelbase m2 (mm)		124	124	124
4.33 Aisle width for pallets (l6-b12) 1000 x 1200 crossways Ast (mm)		3670	3718	3751
4.34 Aisle width for pallets (l6-b12) 800 x 1200 lengthways Ast (mm)	3865	3913	3951	
4.35 Outside turning radius Wa (mm)	2073	2121	2154	
4.36 Internal turning radius b13 (mm)	571	571	571	
Performances	5.1 Travel speed laden/unladen km/h	17.2/17.6	17.2/17.6	17.2/17.6
	5.2 Lift speed laden/unladen m/s	0.670/0.685	0.660/0.685	0.650/0.685
	5.3 Lowering speed laden/unladen m/s	0.45/0.42	0.45/0.42	0.45/0.42
	5.6 Max. drawbar pull laden/unladen *3 *4 N	18286/7613	18394/7171	18717/6916
	5.8 Max. gradeability laden/unladen *3 *4 %	47.6/21.1	41.8/19.8	40.3/17.1
	5.10 Service brake	Drum&Shoe	Drum&Shoe	Drum&Shoe
I.C.- Engine	7.1 Manufacturer/Type	HMC 2.4	HMC 2.4	HMC 2.4
	7.2 Rated output acc. To SAE J1349 kW	38.0	38.0	38.0
	7.3 Rated speed min-1	2500	2500	2500
	7.4 No. of cylinders/displacement /cm3	4/2359	4/2359	4/2359
	7.5 Fuel consumption acc. VDI-Cyclus Diesel = l/h, LPG = kg/h	-	-	-
Miscellaneous	8.2 Operating pressure for attachments bar	max. 140	max. 140	max. 140
	8.3 Oil volume for attachments l/min	max. 35	max. 35	max. 35
	8.4 Sound level, driver's ear acc. EN 12053 dB (A)	79	79	79
	8.5 Towing coupling, class/type DIN	PIN	PIN	PIN

*1) Optional with super-elastic tyres *2) Further lift heights see upright table *3) With 1.6 km/h *4) Without load at friction coefficient $\mu = 0.6$

*5) Height overheadguard with Radio +60m

PRODUCT DESCRIPTION



The C15-20s LPG forklifts are extremely robust and durable in design. Due to their compact dimensions, the trucks are suitable for both outdoor and indoor use. The low maintenance costs, the high availability as well as the long service life of the trucks make them an asset for all kind of companies.

Driver's Compartment

The driver accesses the operator compartment via a large, low, perforated non-slip metal step. A grab handle on the driver's side of entry makes it easy to climb up and down the truck. The floor covering in the footwell is made of non-slip material and ensures a high degree of slip resistance. The tiltable steering column and an easily adjustable comfort seat with excellent legroom ensure optimal adjustment to the driver's individual body size. The foot pedals are arranged in the same way as a car. The ergonomic control levers are smooth and predictable to operate, allowing the driver to concentrate on his work. The clear display shows the operating data in real time. A well-thought-out arrangement of chains and hoses on the mast provide the operator with a large field of vision. Easily accessible storage compartments and an intuitive, foot-operated parking brake complete the operator's station.

Engine, Transmission

The HMC 2.4 LPG engine complies with the EU exhaust gas regulations and is equipped with a 3-way catalytic converter as standard. The HMC LPG engine is durable and easy to maintain, as it has a timing chain. This engine variant is based on a continuously variable automatic CLARK powershift transmission. Together with the drive axle, this transmission forms a compact, powerful unit and is directly connected to the engine. The temperature of both the engine and the transmission is monitored. If limit values are exceeded, the engine is switched off for safety.

Brake System

A self-adjusting drum brake as a service and parking brake ensures high safety with minimal maintenance. Relaxed and concentrated work is possible, as only a small amount of force is required to apply the service brake.

Steering System

The hydrostatic power steering system makes steering easy, with full lock reached in just a few turns of the steering wheel. Road impacts on the steering wheel are absorbed. The steering axle is pendulum-mounted in rubber/steel elements. The short track rods require no adjustment and, together with the steering cylinder, guarantee precise and durable straight-line steering. The kingpins are mounted in lubricated taper roller bearings and the track rods in lubricated self-aligning bearings.

Hydraulic System

A full-flow return filtration system filters the oil on every return to the tank. Coarse particles are filtered directly via an intake filter and do not enter the oil circuit in the first place. This ensures the longevity of all hydraulic components. A high-performance pump supplies the oil for the most functions and the hydrostatic steering. The steering circuit is primarily supplied via a flow distributor. The load is handled by a sensitive and precisely responding control valve. Additional safety is provided by the power break safety device, which prevents uncontrolled lowering of the load.

Upright

The clear-view masts are available in standard, hi-lo and triplex versions. The nested profiles provide high strength even under the heaviest loads. The inclined mast rollers are easily accessible for adjustment work. The tilt cylinders are mounted in self-aligning bearings, which increases the service life of the complete cylinder. An integrated tilt lock valve prevents the mast from tilting forward too quickly or unintentionally. The forks with hook suspension are forged and held in the desired position by adjustable locks. The CLARK mast damping reduces shocks and vibrations during the transition between the individual mast steps. This protects both the goods and the truck. The robust 6-roller fork carriage underlines the durability of this design even in tough applications.

Standard Equipment

Working lights, flashing lights at the front, pneumatic tyres, rear combination light with brake light and reversing light white, vinyl seat, paint in the bright safety colour „CLARK Green“, driver's compartment, lift mast and rims in black.

Additional Equipment

SE tyres (6.5 - 10), non-marking tyres (6.5 - 10), attachments, cab variants with heating, integrated or hook-on side shifts, additional hydraulic functions, quick-change couplings, rear-view mirrors, strobe lights, various seats, reversing handle with horn, swivelling gas bottle holder, vertical exhaust, additional storage compartment and much more.

Security

The C15-20s series is CE certified and complies with all European safety standards for industrial trucks.

Talk to your CLARK dealer to find the optimum equipment for your requirements.